

Model 108 FLEX-AUGER[®] Feed Delivery System

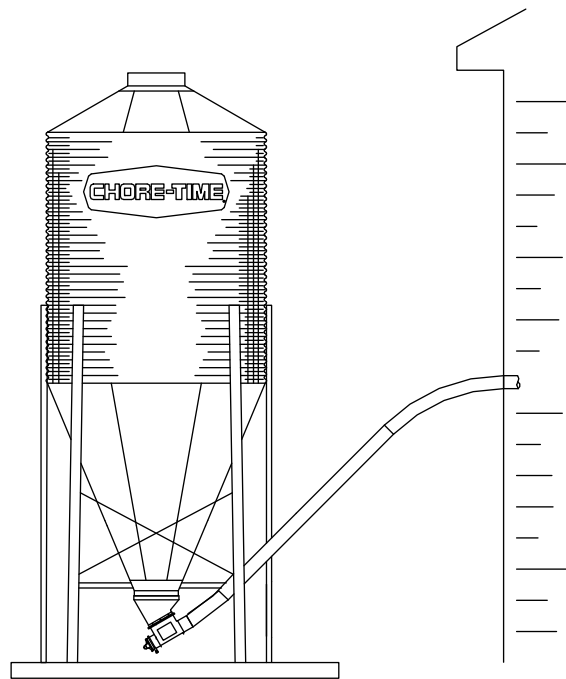

Installation and Operators Manual

Installation and Operators Manual

For additional parts and information, contact your nearest Chore-Time distributor or representative.
Find your nearest distributor at: www.choretime.com/contacts

CTB, Inc.
PO Box 2000
Milford, Indiana 46542-2000 USA
Phone (574) 658-4101 Fax (877) 730-8825
Email: choretime@choretime.com
Internet: www.choretime.com

Limited Warranty

LIMITED WARRANTY

Chore-Time Group, a division of CTB, Inc. (“Chore-Time”) warrants CHORE-TIME FLEX-AUGER® Feed Delivery System components manufactured by Chore-Time to be free from defects in material or workmanship under normal usage and conditions, for One (1) year from the date of installation by the original purchaser (“Warranty”). Chore-Time provides for an extension of the aforementioned Warranty period (“Extended Warranty Period”) with respect to certain Product parts. If such a defect is determined by Chore-Time to exist within the applicable period, Chore-Time will, at its option, (a) repair the Product or Component Part free of charge, F.O.B. the factory of manufacture or (b) replace the Product or Component Part free of charge, F.O.B. the factory of manufacture. This Warranty is not transferable, and applies only to the original purchaser of the Product.

CONDITIONS AND LIMITATIONS

THIS WARRANTY CONSTITUTES CHORE-TIME’S ENTIRE AND SOLE WARRANTY AND CHORE-TIME EXPRESSLY DISCLAIMS ANY AND ALL OTHER WARRANTIES, INCLUDING, BUT NOT LIMITED TO, EXPRESS AND IMPLIED WARRANTIES, INCLUDING, WITHOUT LIMITATION, WARRANTIES AS TO MERCHANTABILITY OR FITNESS FOR PARTICULAR PURPOSES. CHORE-TIME shall not be liable for any direct, indirect, incidental, consequential or special damages which any purchaser may suffer or claim to suffer as a result of any defect in the Product. Consequential or Special Damages as used herein include, but are not limited to, lost or damaged products or goods, costs of transportation, lost sales, lost orders, lost income, increased overhead, labor and incidental costs, and operational inefficiencies. *Some jurisdictions prohibit limitations on implied warranties and/or the exclusion or limitation of such damages, so these limitations and exclusions may not apply to you. This warranty gives the original purchaser specific legal rights. You may also have other rights based upon your specific jurisdiction.*

Compliance with federal, state and local rules which apply to the location, installation and use of the Product are the responsibility of the original purchaser, and CHORE-TIME shall not be liable for any damages which may result from non-compliance with such rules.

The following circumstances shall render this Warranty void:

- Modifications made to the Product not specifically delineated in the Product manual.
- Product not installed and/or operated in accordance with the instructions published by the CHORE-TIME.
- All components of the Product are not original equipment supplied by CHORE-TIME.
- Product was not purchased from and/or installed by a CHORE-TIME authorized distributor or certified representative.
- Product experienced malfunction or failure resulting from misuse, abuse, mismanagement, negligence, alteration, accident, or lack of proper maintenance, or from lightning strikes, electrical power surges or interruption of electricity.
- Product experienced corrosion, material deterioration and/or equipment malfunction caused by or consistent with the application of chemicals, minerals, sediments or other foreign elements.
- Product was used for any purpose other than for the care of poultry and livestock.
-

The Warranty and Extended Warranty may only be modified in writing by an officer of CHORE-TIME. CHORE-TIME shall have no obligation or responsibility for any representations or warranties made by or on behalf of any distributor, dealer, agent or certified representative.

Effective: April 2014

Contents

Topic	Page
Limited Warranty	2
Safety Information	4
Follow Safety Instructions.....	4
Decal Descriptions.....	4
General	5
Capacities and Specifications of the 108 FLEX-AUGER® Feed Delivery System.....	6
Planning	7
Planning the Feed Delivery System.....	7
Typical System Installations.....	9
Model 108 Flex-Auger® Systems Bin Placement Chart.....	10
Model 108 FLEX-AUGER® Systems Bin Placement Chart.....	11
Straight-Out Bin Boot with Feed Screener.....	12
Installation	14
Auger Tube Installation.....	15
Outlet Drop Installation.....	17
Supporting the System Inside the Building.....	18
Supporting the System Outside the Building.....	19
Control Unit & Power Unit Installation.....	22
Belt Drive Control Unit Installation.....	23
Auger Installation.....	24
Cover Plate Installation.....	25
Auger Brazing/Filing.....	25
Restrictor Adjustment.....	26
Straight-Through Tandem Boot.....	27
Operation	32
Start-Up Procedure for New Systems.....	32
Parts Listing	33
Miscellaneous Line Components.....	33
Model 108 Drop Kit (34358).....	34
Power Unit Assembly Part Numbers.....	34
Power Units.....	35
Single Phase Direct Drive Control Unit (Part No. 46800-5).....	36
3-Phase International Direct Drive Control Units (Part No. 46800-10).....	36
Switch Plate & Assembly (Part No. 46051).....	37
Belt Drive Control Unit (Part No. 46138-2).....	38
Model 108 Boot Components.....	39
Model 108 Boot Components.....	40
Troubleshooting	42
Maintenance	44
Oil Recommendation.....	44
Livestock and Poultry Feed Consumption	45

Safety Information

Caution, Warning and Danger Decals have been placed on the equipment to warn of potentially dangerous situations. Care should be taken to keep this information intact and easy to read at all times. Replace missing or damaged safety decals immediately.

Safety–Alert Symbol



This is a safety–alert symbol. When you see this symbol on your equipment, be alert to the potential for personal injury. This equipment is designed to be installed and operated as safely as possible...however, hazards do exist.

Understanding Signal Words

Signal words are used in conjunction with the safety–alert symbol to identify the severity of the warning.



DANGER indicates an imminently hazardous situation which, if not avoided, **WILL** result in death or serious injury.



WARNING indicates a potentially hazardous situation which, if not avoided, **COULD** result in death or serious injury.



CAUTION indicates a hazardous situation which, if not avoided, **MAY** result in minor or moderate injury.

Follow Safety Instructions

Carefully read all safety messages in this manual and on your equipment safety signs. Follow recommended precautions and safe operating practices.

Keep safety signs in good condition. Replace missing or damaged safety signs.

Decal Descriptions

DANGER: Moving Auger

This decal is placed on the End Cap Weldment and Clean-out cover. Severe personal injury will result, if the electrical power is not disconnected, prior to servicing the equipment.

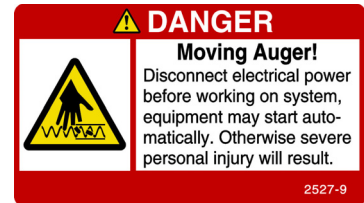

DANGER: Electrical Hazard

Disconnect electrical power before inspecting or servicing equipment unless maintenance instructions specifically state otherwise.

Ground all electrical equipment for safety.

All electrical wiring must be done by a qualified electrician in accordance with local and national electric codes.

Ground all non-current carrying metal parts to guard against electrical shock.

Electrical disconnects and over current protection are not supplied with the equipment.

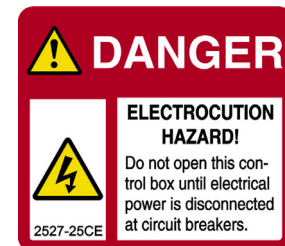

DANGER: Springing Auger

Use caution when working with Auger. Springing Auger may cause personal injury.

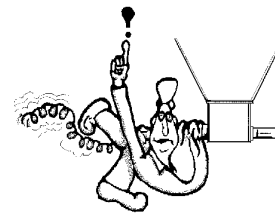

Attention: Read the Manual

See the manual for detailed installation instructions.



General

The CHORE-TIME FLEX-AUGER® Feeding System is designed to convey poultry and livestock feed types. Using this equipment for any other purpose or in a way not within the operating recommendations specified in this manual will void the warranty and may cause personal injury and/or death.

This manual is designed to provide comprehensive planning, installation, wiring, and parts listing information. The Table of Contents provides a convenient overview of the information in this manual. The Table of Contents also specifies which pages contain information for the sales personal, installer, and consumer (end user).

IMPORTANT: CE stands for certified Europe. It is a standard which equipment must meet or exceed in order to be sold in Europe. CE provides a benchmark for safety and manufacturing issues. CE is required only on equipment sold in Europe.



CHORE-TIME Equipment recognizes CE Mark and pursues compliance in all applicable products. Any alterations to the products will violate the CE compliance, will void the warranty, and may cause personal injury and/or death.

Please include the names and address of your CHORE-TIME Distributor.

Please fill in the following information about your Chore-Time FLEX-AUGER® Feeding System.
Keep this manual in a clean, dry place for future reference.

Distributor's Name _____

Distributor's Address _____

Distributor's Phone _____ **Date of Purchase** _____

Installer's Name _____

Installer's Address _____

Installer's Phone _____ **Date of Installation** _____

System Specifications _____

Feed Delivery System Supplying

Please read the installation instructions in this manual prior to beginning the installation. This manual is designed to provide the information necessary for the installation, operation, and maintenance of the Model 108 Feed Delivery System.

Please pay special attention to the danger decals and caution information, they are there for YOUR PROTECTION.

Capacities and Specifications of the 108 FLEX-AUGER® Feed Delivery System

The Model 108 FLEX-AUGER® Feed Delivery System is available with either PVC or steel auger tubes. PVC and steel tubes should not be mixed in a system.

DO NOT USE PVC AUGER TUBING WITH FEEDS CONTAINING CALCIUM. The steel auger tubes should be used for feeds with calcium.

The Model 108 FLEX-AUGER® Feed Delivery System has an approximate conveying capacity* of 220 pounds per minute (100 kg per minute), or 13,200 pounds per hour (6,000 kg per hour). A high capacity Model 108 system may be ordered for applications requiring up to 250 pounds per minute (113 kg per minute). The maximum recommended running time per day is 4 hours.

*Carrying capacities are based on feed density of 40 pounds per cubic foot or 640 kg per cubic meter.

The Model 108 is designed to carry feeds such as mash, crumbles, shelled corn, high moisture corn, or pellets up to approximately 3/16" x 1/2" (4.7 x 12.7 mm) in size. Applications other than conveying poultry and livestock rations will void the warranty.

Adequate support must be provided to prevent the tubes from sagging and support the weight of the Control Unit. The auger, tubes, and feed weigh approximately 8 lbs/ft. (12 kg/m). The Control Unit weighs approximately 100 lbs. (45 kg).

**MAXIMUM MOISTURE CONTENT OF CORN FOR THE MODEL 108 FLEX-AUGER® IS 27%.
MAXIMUM MOLASSES CONTENT IS 2%.**

Planning

Planning the Feed Delivery System

Carefully plan the Model 108 Fill System installation. Make sure the system will not interfere with other equipment, doors, windows, etc.

The charts below provide power unit recommendations and maximum system line lengths. The top chart applies to standard 348 RPM systems. The lower chart applies to (optional) High Capacity 425 RPM systems.

**Maximum Line Lengths*
for standard 348 RPM Systems**

Motor HP	Standard System	Extended System
3/4	50 Ft. (15.2 m)	75 Ft. (22.8 m)
1	100 Ft. (30.5 m)	135 Ft. (41.1 m)
1-1/2	150 Ft. (45.7 m)	185 Ft. (56.4 m)

High Moisture Corn Installations:
Reduce the line length capacity for each Power Unit by 50% in high moisture corn applications

Maximum Line Lengths* for High Capacity 425 RPM Systems

Motor HP	Standard System	Extended System
1	50 Ft. (15.2 m)	75 Ft. (22.8 m)
1-1/2	100 Ft. (30.5 m)	135 Ft. (41.1 m)
2	150 Ft. (45.7 m)	185 Ft. (56.4 m)

Straight-Thru Tandem Installations:
Reduce the line length by 50 ft. (15.2 m) for Straight-Through Tandem Systems.

*Maximum line lengths should be reduced for elevations over 8' (2.4 m) and/or inclines steeper than 45 degrees.

Maximum lengths for 108 systems include use of two PVC elbows. If additional elbows are used, decrease line length by 30 ft. (9 m) per elbow. Length of extension systems do not include elbows. Decrease maximum extension system lengths by 30 ft. (9 m) per elbow if used in the system.

Horsepower requirements are based on length of the Model 108 FLEX-AUGER® system and type of system installed--i.e. number of turns.

See the sections starting with “**Model 108 Flex-Auger® Systems Bin Placement Chart**” on page 10 for typical bin to building placement using various elevations, boots, and screener options.

1. For the easiest installation and most trouble-free operation, locate the feed bin in a direct line with the FLEX-AUGER® Feed Delivery System. The layout charts on page 10 and page 11 provide some points of reference for bin placement according to the height at which the FLEX-AUGER® tube enters the building. Remember, these are only examples. The layouts can be modified by changing the elbows, the tube sections, and/or the distance from the bin to the building.

FLEX-AUGER® Feed Delivery Systems operate best at an angle of no more than 60 degrees from horizontal to the entry of the building at the desired height. **Chore-Time considers a 45 degree elevation to be standard. The lower the angle, the more reliable the system.**

2. Lay out the system as straight as possible. Avoid extra elbows and curves by locating the feed bin in line with the feeders. One horizontal 90 degree turn is permissible inside the building. **180 degree turns are not recommended under any conditions.**
If additional turns or elbows are required, use an Extension Boot. **Remember: one 90 degree elbow requires the same power as 30' (9.1 m) of straight line.**
3. Plan the system so that the auger tubes are directly over the feeders or hoppers to be filled, if possible. The drop tubes may be angled to a maximum of 45 degrees from the vertical if necessary. At angles greater than 45 degrees, bridging in the drop tubes may occur.
4. The control unit must be located over a feeder or hopper that will require as much or more feed than any of the other feeders or hoppers. If frequent filling is desired, mount the drop tube switch or hopper level switch low so that this feeder or hopper will have a low feed level. This allows the feeder to call for feed more often, the system will restart, and the other feeders will be refilled sooner.
5. Do not locate outlet drops on or just before an elbow. Install the drop after the elbow so feed will cushion the auger through the curve. If there is some reason why the outlet drop cannot be moved, it must have some "feed bypass" to cushion the auger through the elbow.
6. Avoid horizontal left-hand turns if possible. The elbow in a left-hand turn is not cushioned by the feed and will wear faster. On systems with a 90 degree horizontal left-hand turn, reduce the stretch to reduce wear.
NOTE: A rule of thumb for left-hand turns is to reduce stretch to 6" per 50' (150 mm per 15 m) of auger on initial installation. After the system has been broken in, it may be necessary to increase the auger stretch to prevent auger surging.
7. On any Extended Length System, balance the power requirements between the power unit that takes feed from the bin and the power unit on the Extended Length System.

To do this, determine the total length of the system and divide by two. Subtract 20' (6.1 m) from the standard system and add 20' (6.1 m) to the extended system.

Example: On a 240' (73 m) system, the center of the system would be 120' (36.5 m). Subtract 20' (6.1 m) from standard system, and add it to the extended length system. The first power unit should be located approximately 100' (30 m) down the system. Locate the second power unit approximately 140' (42.7 m) from the first power unit.

Typical System Installations

The FLEX-AUGER® Delivery Systems may be readily adapted to most feed delivery applications. The systems illustrated below show the most common types of FLEX-AUGER installations. These diagrams provide guidelines for laying out your system.

There are Five Recommended and Non Recommended Layouts shown below. Possible alternate systems are provided with each non-recommended system.

Recommended Layouts

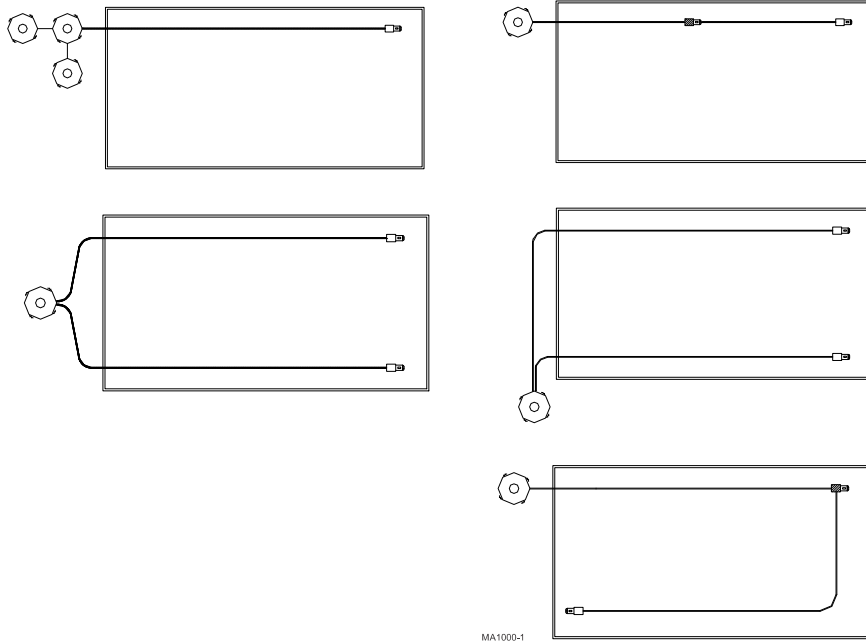

MA1000-1

Non Recommended Layouts

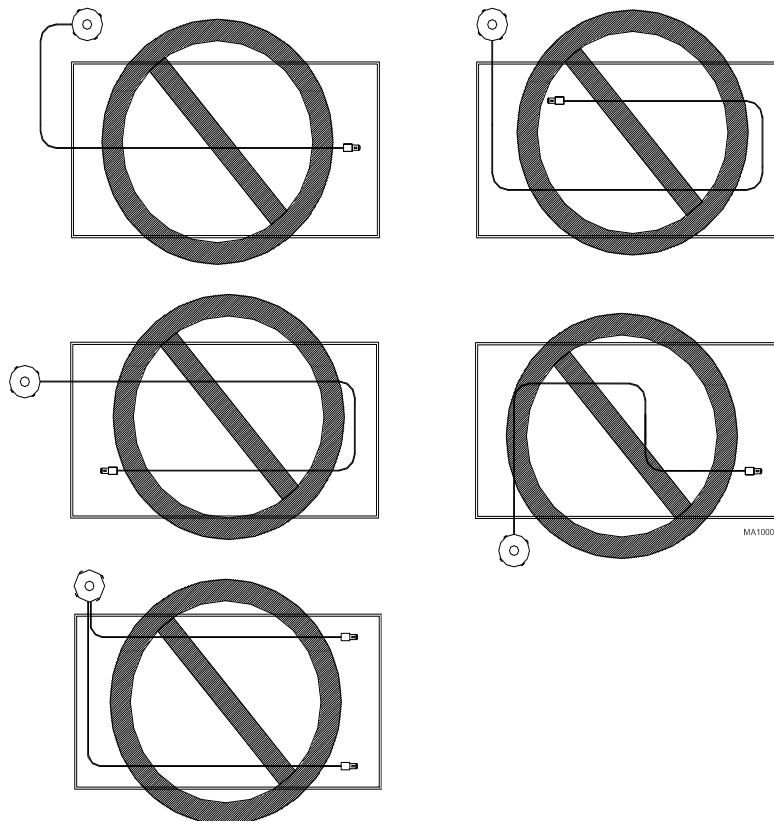

MA1000-2

Model 108 Flex-Auger® Systems Bin Placement Chart

Use this chart to determine the distance from building to center of bin ("X") at the various entrance heights ("H") and degrees of elevations listed below.

Degree of elevation = Angle at which the system is installed, including the 30 degree or straight-out Upper Boot.

These layout charts are for planning and reference purposes only. A combination of elbows and straight tube may be required for your installation, depending on the distance from the bin to the building and the height at which the auger tubes are to enter the building. The elbows may be easily cut to any angle required.

PAY PARTICULAR ATTENTION TO THE MINIMUM DISTANCE BETWEEN THE BIN AND THE BUILDING.

Many installation and operational difficulties can be avoided if the bin is located farther from the building. If in doubt, it is **BETTER TO BE TOO FAR AWAY THAN TOO CLOSE.**

The maximum recommended angle of elevation above the horizontal is 60 degrees. The maximum elevation is 30 feet (9.1 m) . . . if the angle of elevation is no more than 45 degrees.

All systems require adequate support of the auger tubes to prevent sagging and/or excessive forces being transmitted to the bin boot.

System Model	Entrance Height "H"	Distance from Center of Bin to the Building "X"					
		30 Degree Upper Bin Boot (part no. 4347)			Straight-Out Upper Bin Boot (part no. 6093)		
		30 Degree	45 Degree	60 Degree	30 Degree	45 Degree	60 Degree
Model 108	5' (1.5 m)	9' (2.7 m)	-----	-----	11.5' (3.5 m)	10' (3 m)	-----
	6' (1.8 m)	11' (3.4 m)	8.5' (2.6 m)	8' (2.4 m)	13.5' (4.1 m)	11' (3.4 m)	10' (3 m)
	7' (2.1 m)	12.5' (3.8 m)	9.5' (2.9 m)	8.5' (2.6 m)	15' (4.6 m)	12' (3.7 m)	11' (3.4 m)
	8' (2.4 m)	14.5' (4.4 m)	10.5' (3.2 m)	9' (2.7 m)	17' (5.2 m)	13' (4 m)	11.5' (3.5 m)
	9' (2.7 m)	16' (4.9 m)	11.5' (3.5 m)	9.5' (2.9 m)	18.5' (5.6 m)	14' (4.3 m)	12' (3.7 m)
	10' (3 m)	17.5' (5.3 m)	12.5' (3.8 m)	10' (3 m)	20' (6.1 m)	15' (4.6 m)	12.5' (3.8 m)
	11' (3.4 m)	19.5' (5.9 m)	13.5' (4.1 m)	10.5' (3.2 m)	22' (6.7 m)	16' (4.9 m)	13' (4 m)
	12' (3.7 m)	21' (6.4 m)	14.5' (4.4 m)	11.5' (3.5 m)	23.5' (7.2 m)	17' (5.2 m)	13.5' (4.1 m)
	13' (4 m)	23' (7 m)	15.5' (4.7 m)	12' (3.7 m)	25.5' (7.8 m)	18' (5.5 m)	14' (4.3 m)
	14' (4.3 m)	24.5' (7.5 m)	16.5' (5 m)	12.5' (3.8 m)	27' (8.2 m)	19' (5.8 m)	15' (4.6 m)
	15' (4.6 m)	26.5' (8.1 m)	17.5' (5.3 m)	13' (4 m)	29' (8.8 m)	20' (6.1 m)	15.5' (4.7 m)
	16' (4.9 m)	28' (8.5 m)	18.5' (5.6 m)	13.5' (4.1 m)	30.5' (9.3 m)	21' (6.4 m)	16' (4.9 m)
	17' (5.2 m)	30' (9.1 m)	19.5' (5.9 m)	14' (4.3 m)	32.5' (9.9 m)	22' (6.7 m)	16.5' (5 m)
	18' (5.5 m)	31.5' (9.6 m)	20.5' (6.2 m)	14.5' (4.4 m)	34' (10.4 m)	23' (7 m)	17' (5.2 m)
	19' (5.8 m)	33.5' (10.2 m)	21.5' (6.5 m)	15.5' (4.7 m)	36' (11 m)	24' (7.3 m)	17.5' (5.3 m)
	20' (6.1 m)	35' (10.7 m)	22.5' (6.8 m)	16' (4.9 m)	37.5' (11.4 m)	25' (7.6 m)	18.5' (5.6 m)

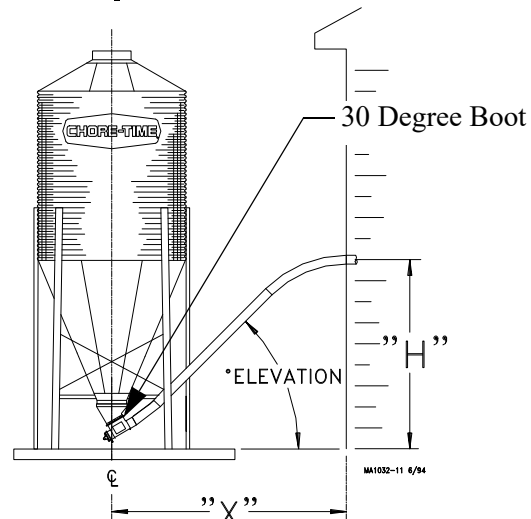
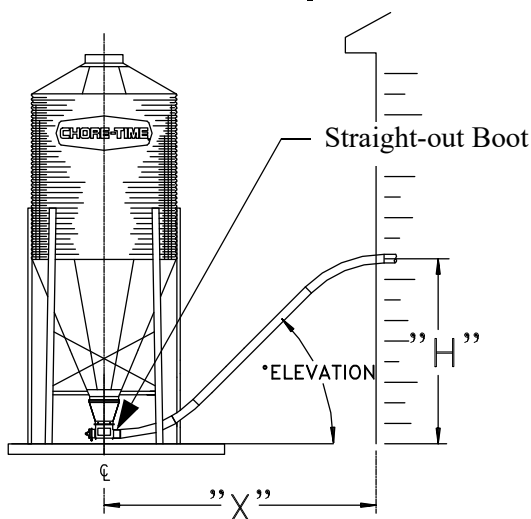

Model 108 FLEX-AUGER® Systems Bin Placement Chart (with In-Line or Rotated Screeners)

Use this diagram and chart to determine proper feed bin placement when using screener.

"X" = distance from center of bin to where fill system enters the building.

"H" = height from top of bin pad to where fill system enters the building.

Degree of elevation = Angle at which the system is installed (from horizontal).

System shown with screener boot installed in-line; system may also be installed with the screener boot rotated 90 degrees.

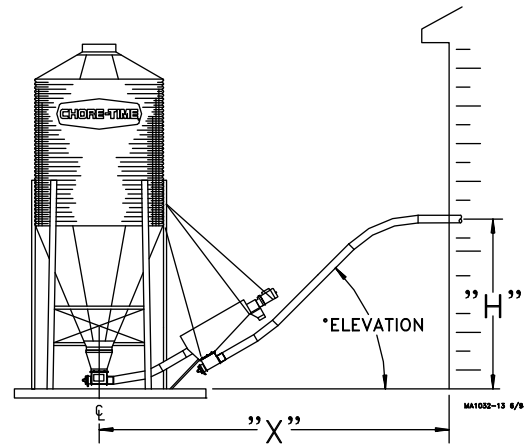
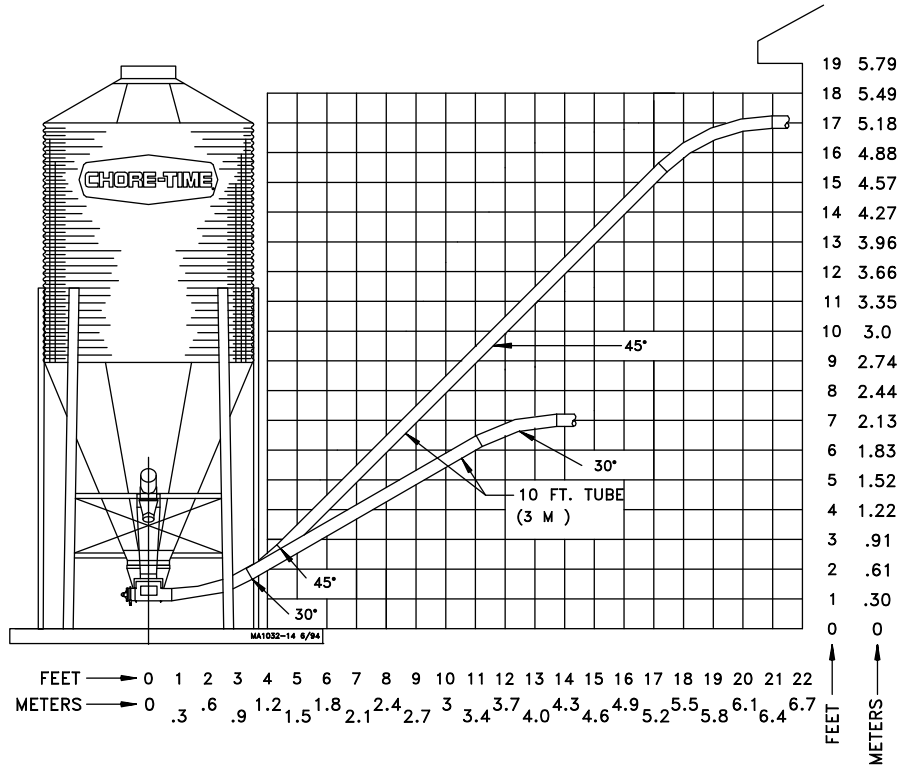

Chart for minimum distances ("X") from building to center of bin using the various entrance heights ("H"), upper boots and elevations listed below.

System Model	Entrance Height "H"	30 Degree Upper Bin Boot (part no. 4347)		Straight-Out Upper Bin Boot (part no. 6093)		
		30 Degree	45 Degree	30 Degree	45 Degree	
Model 108 using Screener Screener Boot is in-line with System	5' (1.5 m)	12.5' (3.8 m)	11.5' (3.5 m)	15' (4.6 m)	14' (4.3 m)	
	6' (1.8 m)	14' (4.3 m)	12.5' (3.8 m)	16.5' (5 m)	15' (4.6 m)	
	7' (2.1 m)	16' (4.9 m)	13.5' (4.1 m)	18.5' (5.6 m)	16' (4.9 m)	
	8' (2.4 m)	17.5' (5.3 m)	14.5' (4.4 m)	20' (6.1 m)	17' (5.2 m)	
	9' (2.7 m)	19.5' (5.9 m)	15.5' (4.7 m)	22' (6.7 m)	18' (5.5 m)	
	10' (3 m)	21' (6.4 m)	16.5' (5 m)	23.5' (7.2 m)	19' (5.8 m)	
	11' (3.4 m)	23' (7 m)	17.5' (5.3 m)	25.5' (7.8 m)	20' (6.1 m)	
	12' (3.7 m)	24.5' (7.5 m)	18.5' (5.6 m)	27' (8.2 m)	21' (6.4 m)	
	13' (4 m)	26.5' (8.1 m)	19.5' (5.9 m)	29' (8.8 m)	22' (6.7 m)	
	14' (4.3 m)	28' (8.5 m)	20.5' (6.2 m)	30.5' (9.3 m)	23' (7 m)	
	15' (4.6 m)	29.5' (9 m)	21.5' (6.5 m)	32.5' (9.9 m)	24' (7.3 m)	
	16' (4.9 m)	31.5' (9.6 m)	22.5' (6.8 m)	34' (10.4 m)	25' (7.6 m)	
	17' (5.2 m)	33' (10 m)	23.5' (7.2 m)	35.5' (10.8 m)	26' (7.9 m)	
	18' (5.5 m)	35' (10.7 m)	24.5' (7.5 m)	37.5' (11.4 m)	27' (8.2 m)	
	19' (5.8 m)	36.5' (11.1 m)	25.5' (7.8 m)	39' (11.9 m)	28' (8.5 m)	
	20' (6.1 m)	38.5' (11.7 m)	26.5' (8.1 m)	41' (12.5 m)	29' (8.8 m)	
	Model 108 using Screener Screener Boot is Rotated 90 degrees to System	5' (1.5 m)	11' (3.4 m)	9.5' (2.9 m)	11' (3.4 m)	9.5' (2.9 m)
		6' (1.8 m)	13' (4 m)	10.5' (3.2 m)	13' (4 m)	10.5' (3.2 m)
		7' (2.1 m)	14.5' (4.4 m)	11.5' (3.5 m)	14.5' (4.4 m)	11.5' (3.5 m)
		8' (2.4 m)	16' (4.9 m)	12.5' (3.8 m)	16' (4.9 m)	12.5' (3.8 m)
9' (2.7 m)		18' (5.5 m)	13.5' (4.1 m)	18' (5.5 m)	13.5' (4.1 m)	
10' (3 m)		19.5' (5.9 m)	14.5' (4.4 m)	19.5' (5.9 m)	14.5' (4.4 m)	
11' (3.4 m)		21.5' (6.5 m)	15.5' (4.7 m)	21.5' (6.5 m)	15.5' (4.7 m)	
12' (3.7 m)		23' (7 m)	16.5' (5 m)	23' (7 m)	16.5' (5 m)	
13' (4 m)		25' (7.6 m)	17.5' (5.3 m)	25' (7.6 m)	17.5' (5.3 m)	
14' (4.3 m)		26.5' (8.1 m)	18.5' (5.6 m)	26.5' (8.1 m)	18.5' (5.6 m)	
15' (4.6 m)		28.5' (8.7 m)	19.5' (5.9 m)	28.5' (8.7 m)	19.5' (5.9 m)	
16' (4.9 m)		30' (9.1 m)	20.5' (6.2 m)	30' (9.1 m)	20.5' (6.2 m)	
17' (5.2 m)	32' (9.8 m)	21.5' (6.5 m)	32' (9.8 m)	21.5' (6.5 m)		
18' (5.5 m)	33.5' (10.2 m)	22.5' (6.8 m)	33.5' (10.2 m)	22.5' (6.8 m)		
19' (5.8 m)	35.5' (10.8 m)	23.5' (7.1 m)	35.5' (10.8 m)	23.5' (7.2 m)		
20' (6.1 m)	37' (11.3 m)	24.5' (7.4 m)	37' (11.3 m)	24.5' (7.5 m)		

Straight-Out Bin Boot with Feed Screener (Boot Rotated 90°)



30° Bin Boot with Feed Screener

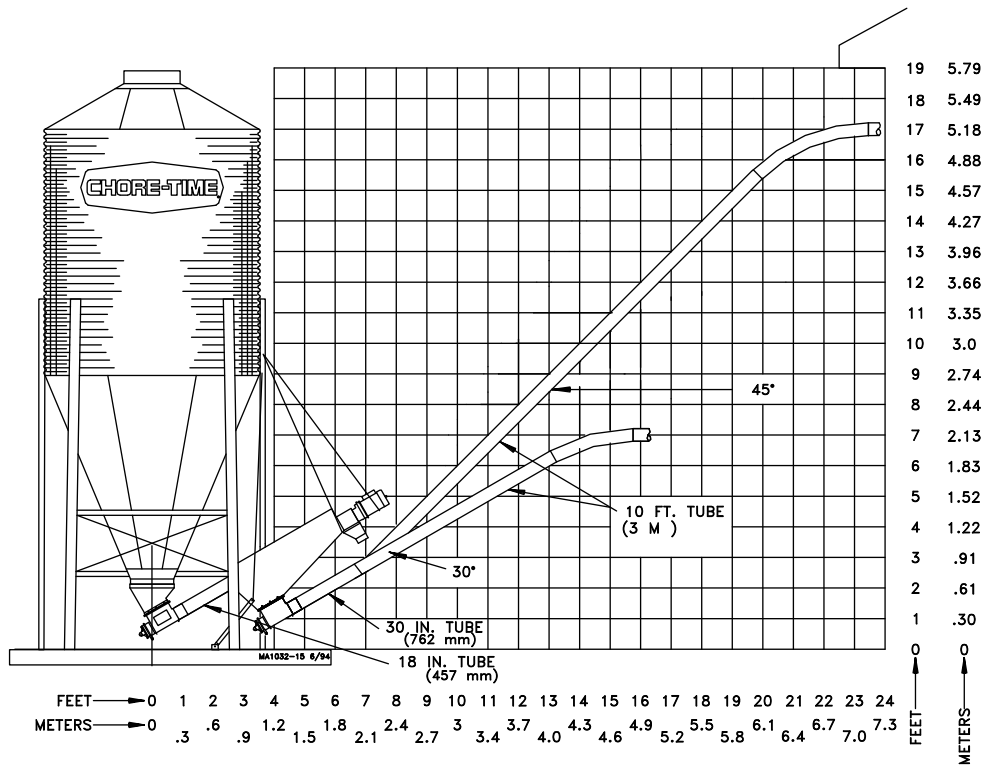

Straight-Out Bin Boot with Feeder Screener

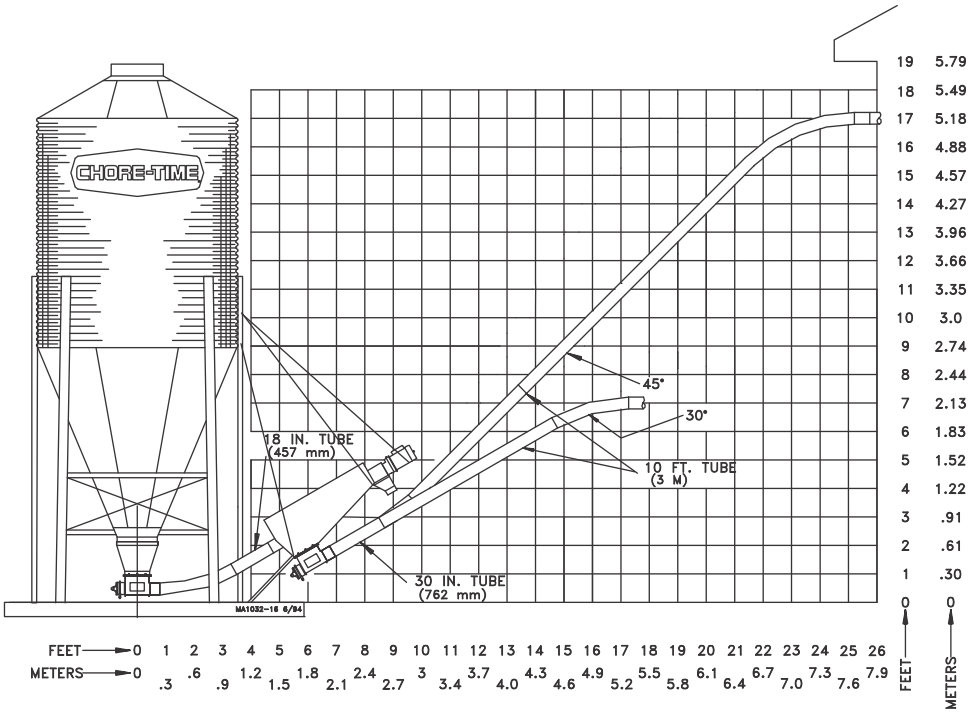

Installation

Bin Location Information

For easiest installation and most trouble-free operation, locate the feed bin directly in line with the FLEX-AUGER® System. The “**Model 108 Flex-Auger® Systems Bin Placement Chart**” on pages 10-13 provide some points of reference for bin placement according to the height at which the system enters the building. The 30 degree or straight-out boots combined with various elbow hookups offer a wide range of possibilities. The charts are only for reference. Modify and adjust elbows and tube sections as needed.

NOTE: Two 45 degree PVC elbows are standard with Model 108 FLEX-AUGER® Delivery Systems. If additional elbows are required they must be ordered separately.

The bin collar is installed during bin assembly. Chore-Time bins have a welded collar. Bin Adapter Kits are available to modify existing bins so that the welded collar can be used. In addition, a Universal Adapter Plate is available to allow the FLEX-AUGER® boot to be installed to other manufacturers’ bins.

Tighten all bin-seal bolts from the nut side. This prevents cutting and "spinning out" of the plastic washer.

Boot Installation

1. Insert the upper boot into the bin collar and turn it to line up with the direction that the auger line will go. The boot must be as far up into the opening as it will go. Use the holes in the ring for drilling guides and drill 11/32" (8.8 mm) holes in the upper rim of the boot. Attach the boot to the bin collar with the hardware provided. See Figure 1.

IMPORTANT: Failure to install the hardware as shown in Figure 1 may cause breakage of the red boot body.

2. Attach the transfer plate to the upper boot. Use truss head bin-seal bolts installed from the inside of the plate, with flat washers placed under the nuts.
3. Insert the slide into the transfer plate slot so that it is in its operating position before bolting the slide shield in place. Remove the paper backing from the sealing strip before fastening the slide shield to the transfer plate. Use two 5/16-18x3/4" hex head machine screws to secure the shield.
4. Bolt the lower boot to the transfer plate using four 5/16-18x3/4" hex head machine screws.
5. After the auger tubes and auger have been installed, attach the 6197 Clean-Out Cover Plate or the optional Proximity Boot Switch to the lower boot.

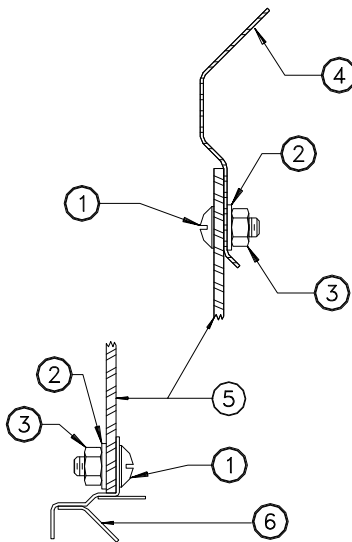

KEY	DESCRIPTION	PART NO.
1	5/16-18 X 3/4" Truss Hd. MS	7943-1
2	5/16" Nylon Washer	7946
3	5/16-18 Nylon Hex Nut	7945
4	Hopper Collar	-
5	Boot Body	-
6	Transfer Plate	-

Figure 1.Boot Installation Diagram (Side View)

MA1032-64 1/95

Auger Tube Installation

The FLEX-AUGER® Delivery System includes two 45 degree elbows as standard equipment. These elbows are used to make up the sloping portion of the auger line at the feed bin, and elsewhere in the system if necessary. If additional elbows are required they should be ordered separately. **Figure 2** shows how the elbow can be cut into shorter sections.

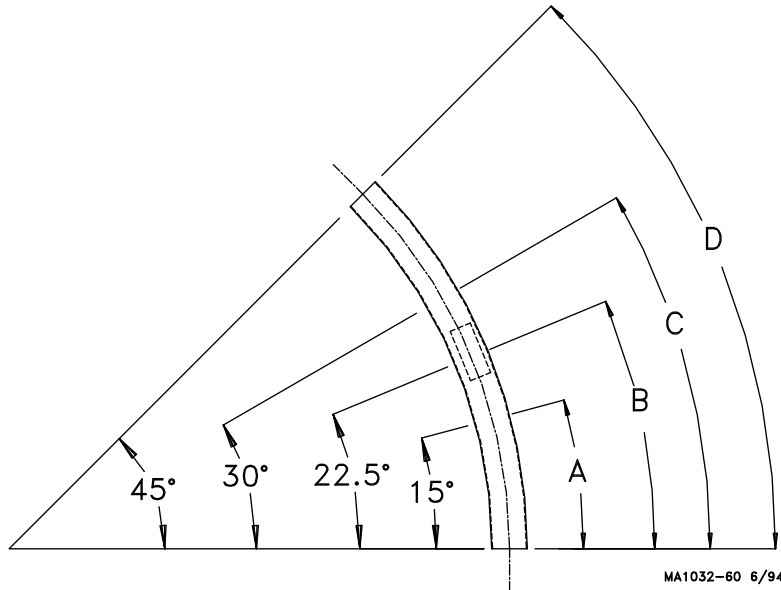

Dimension	PVC	Steel
"A"	16.8" (43 cm)	16.3" (41 cm)
"B"	25.2" (64 cm)	24.4" (62 cm)
"C"	33.6" (85 cm)	32.5" (83 cm)
"D"	50.3" (128 cm)	48.8" (124 cm)

Note: All measurements are along the outside edge of the elbow.

Note: PVC elbows are belled. Dimensions shown do not include bell.

Figure 2. PVC Elbow Cutting Guidelines (Side View)

1. Determine where the entrance hole for the auger tube must be located on the building and cut it.
2. If necessary, cut the elbow used where the auger enters the building. Slide the seal ring and neoprene seal over the straight end of the elbow and place it in the hole cut in the building, with the belled end outside the building. See Figure 3.
3. Clamp the belled end of the second elbow on the outlet end of the boot on the feed bin.
4. Place the straight end of a tube section inside the belled end of the elbow in the building. Hold the straight section of auger tube so that it touches the elbow on the boot. Mark the spot where the tube touches the boot elbow and cut the elbow at that point.
5. Place the belled end of the auger tube over the end of the elbow just cut, and hold the tube against the top elbow. Mark and cut the straight auger tube so that it will fit between the two elbows.

Remember to cut the auger tube long enough to fit inside the belled end of the elbow in the building.

NOTE: In some installations it may be possible to eliminate the elbow on the boot, using only a straight auger tube and one elbow where the auger tube enters the building.

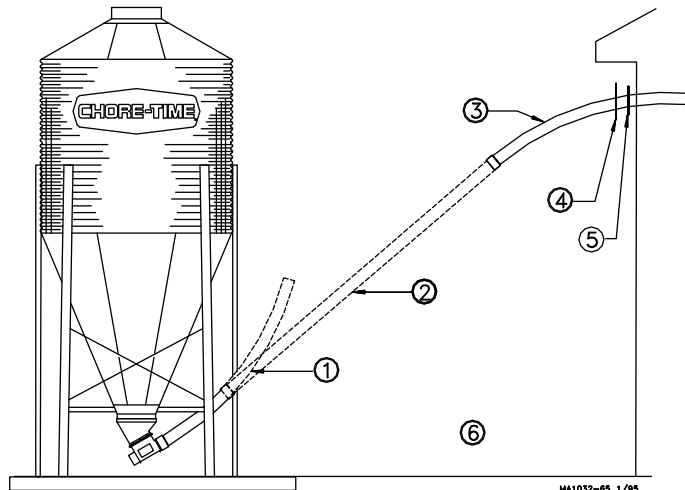

Key	Description
1	45° Elbow
2	Auger Tube
3	45° Elbow
4	Seal Ring
5	Neoprene Seal
6	Note: Belled end of elbows and auger tubes should be towards boot.

Figure 3. Elbow Installation outside the building.

6. Dry-fit all parts. When satisfied that elbows and tubes fit together smoothly, glue with PVC cement according to the following instructions.

The auger tubes and elbows for the FLEX-AUGER® systems are made of specially formulated PVC tubing. Use the PVC solvent cement to make strong, reliable bonds.

Follow the Directions on the can for Safe handling of cement

1. Be sure tube is cut off squarely. Remove burrs from outside and inside the end of the tube.
 2. Dry fit all parts. Tube should fit inside belled end of next tube to full depth without excess force.
 3. Clean surfaces to be joined. SURFACES MUST BE FREE OF DIRT OR GREASE!
 4. Apply a generous coat of cement to both the inside of the belled end and outside of the other tube. Be sure cement covers all of the joint area so there are no bare spots.
 5. Quickly join the tubes, giving them a twisting motion to bring them into alignment as they are joined.
 6. Keep pressure on the joint until the PVC cement sets up.
7. ALL TUBE JOINTS EXPOSED TO MOISTURE AND WEATHER MUST BE SEALED OR CAULKED TO WATERPROOF THEM IN ADDITION TO CEMENTING OR CLAMPING THE JOINT.
 8. If there are more than 15 feet (4.5 meters) of auger tube between the boot and the building, provide additional support for the tubes so that the boot does not carry the weight of the auger. Extra support can be achieved with cables or chain fastened to the bin legs and the auger tube.
 9. Locate and cut the outlet holes as required and specified in **Figure 4. on page 17.**
 10. Slide (2) Outlet Insert Rings onto the pipe at each outlet hole location. Each Outlet Assembly is shipped with Insert Rings for both steel and PVC pipes. The 3/8" (10 mm) thick rings are for steel tube systems. The 1/4" (6 mm) thick rings are for PVC tube systems. Be sure to use the appropriate Insert Rings for your system.
 11. Install the remaining tubes in the system.
The PVC auger tubes should be fastened together using PVC cement.
Model 108 Tube connectors should be used to connect steel auger tubes.

Outlet Drop Installation

Cut the outlet hole in the auger tube. A sabre saw or hacksaw is handy for making the cuts when total feed dropout is desired. See Figure 4. Use a file to remove burrs from opening.

Note: For total feed drop out, outlet holes should be 5-3/8" (137 mm). If some feed carry over is required, outlet holes should be 3-1/2" (90 mm).

See Figure 5. below for outlet drop installation.

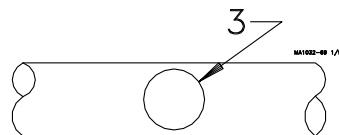
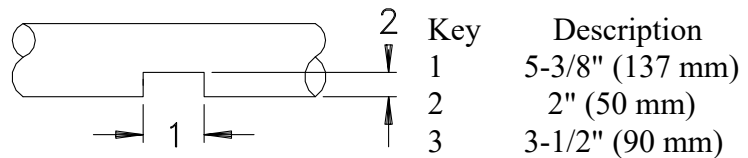
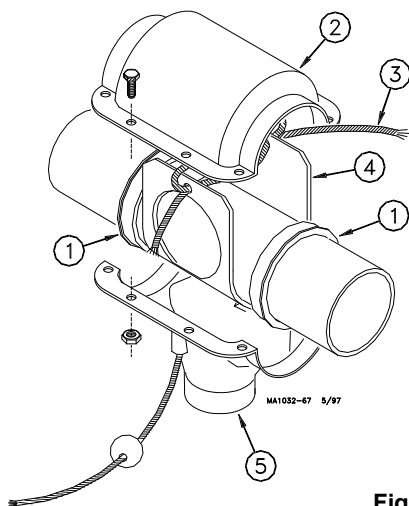

Figure 4.Outlet holes provide total or partial feed dropout

1. Wrap the rotary slide around the auger tube. POSITION SLIDES IN SAME DIRECTION FOR ALL DROPS SO THAT THE SLIDES WILL ALL OPERATE THE SAME WHEN ROPES ARE PULLED.
2. Thread the rope through the ends of the rotary slide.
3. Tie the ends of the rotary slide together so that the ends of the rope are the same length.
4. Open rope guide holes molded into the drop halves. Use a 3/16" (5 mm) drill bit and power drill to make a good hole for the rope.
NOTE: DO NOT OPEN THESE HOLES IF THE ROTARY SLIDE WILL NOT BE INSTALLED.
5. Thread the rope ends through the guide holes in the drop halves.
6. Position drop halves over the rotary slide and fasten the two halves together using hardware provided. See Figure 5.

Insert Rings are provided for both Steel Systems (Thicker Rings) and PVC Systems (Thinner Rings).

Slide the Insert Rings (with Flanges out) into position between the outlet halves to serve as spacers. See Figure 5.



Key	Description
1	Insert (For Steel or PVC System)
2	Top Half
3	Rope
4	Rotary Slide
5	Bottom Half w/Spout

Figure 5.Model 108 Outlet Drop Assembly

7. Test the operation of the rotary slide by pulling on the ends of the rope. Be sure the outlet drop is centered over the outlet hole, then move the rotary slide to the open position (check by looking up through the drop opening) and mark the short end of the rope where it goes through the guide hole.
Tie a knot in the rope at the marked spot to act as a stop for the rotary slide.
8. Install green and red indicator balls on the ends of the rope. Tie knots in the rope to hold the balls in place. Use the green ball on the rope used to open the outlet drop. Use the red ball on the rope used to close the drop. This will indicate if the Outlet Drop is open or closed.
9. Dab PVC cement around the auger tube to prevent the drop from shifting on the tube.
10. Two screws are supplied for use in the bottom of the drop to attach a drop tube to the system.

Supporting the System Inside the Building

Support the Auger Tubing with chain and "S" Hooks every 5 feet [1.5m]. Steel Tube systems require support every 10 feet [3m]. The system should be restrained from swinging by using chain and "S" hooks to brace the auger tube, every 20 feet [6m], as shown in **Figure 6**.

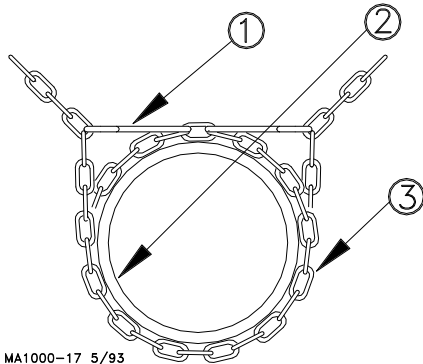

Key	Description
1	"S" Hook
2	Auger Tube
3	Chain

Figure 6.Supporting the Auger Tubes

Horizontal elbows need to be supported in at least two places. Chain, screw hooks, and "S" hooks are supplied as a suspension kit for supporting the equipment. Keep the line as level and straight as possible.

If Extension Hoppers, Outlet Drops with long angled Drop Tubes, or other loads are imposed on the system, extra support will be required.

Power Units require extra support to resist the twisting encountered when the motor starts and stops. Use the motor mount base, all of the "ears" on the gearhead as well as the suspension point provided on the 46800 Control Unit Box to support the Power Unit.

Adequate chain and "S" hooks are provided with each system to properly support it. Other means of supporting the system are permissible as long as the system receives the correct support and the auger tube is not dented or flattened.

When the auger tube passes through a side wall or partition, especially where it enters the building, the opening should be made large enough so the auger tube can be supported without resting on the wall. If the auger tube rests on the wall or partition, the auger tube may flatten out or become kinked--causing excessive wear. **See Figure 7.**

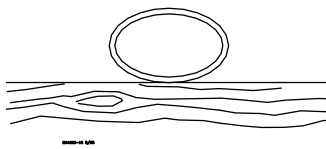

Auger tube kinked because the supports are not high enough to keep the weight of the auger tube off the wall.

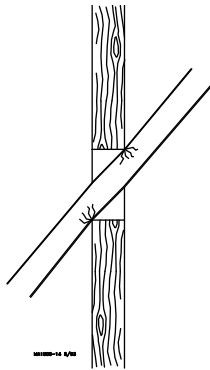

Tube pinched because auger tube is not in line with hole in wall.

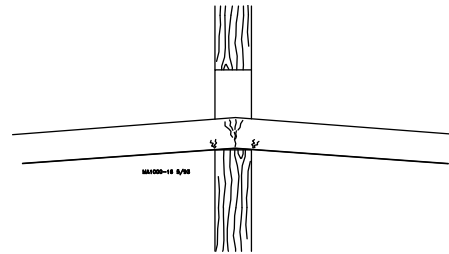

Auger tube flattened because supports are too far away from each side of the wall.

Figure 7.Incorrectly supported Auger Tubes

Supporting the System Outside the Building

Some systems require additional support to avoid sagging auger tubes. This support must be adequate to support the weight of the auger tubes filled with feed. Special attention should be given to avoid excessive pressure from the auger being transferred to boot. Chain or cable suspended from the bin or building will not provide adequate support for these systems.

Some common systems are shown in Figures 8 through 12, with the recommended supports.

Note: Supports must be designed to prevent (weight) loads from being transferred back onto the boot.

The auger tubes must be supported every 4-5 feet (1.2 to 1.5 m) for PVC systems and every 10 feet (3 m) for steel systems.

Screener Support

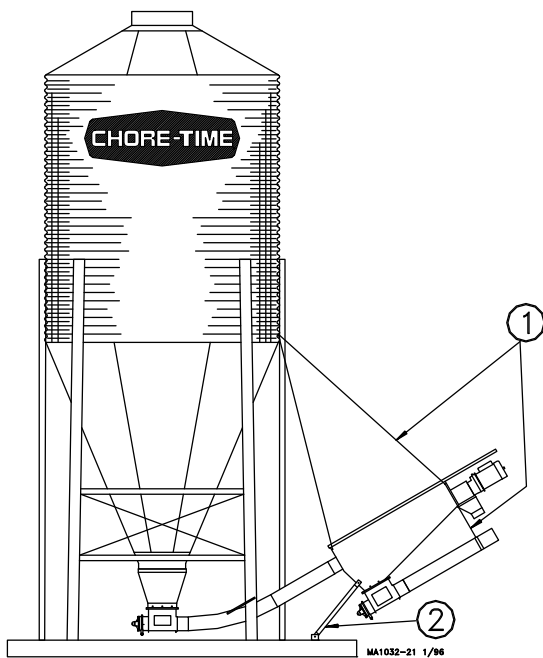

Key	Description
1	5' (1.5 m) for PVC Systems 10' (3 m) for Steel Systems
2	Screener Brace.

Figure 8.Screener Support

High Rise Auger Tube Support

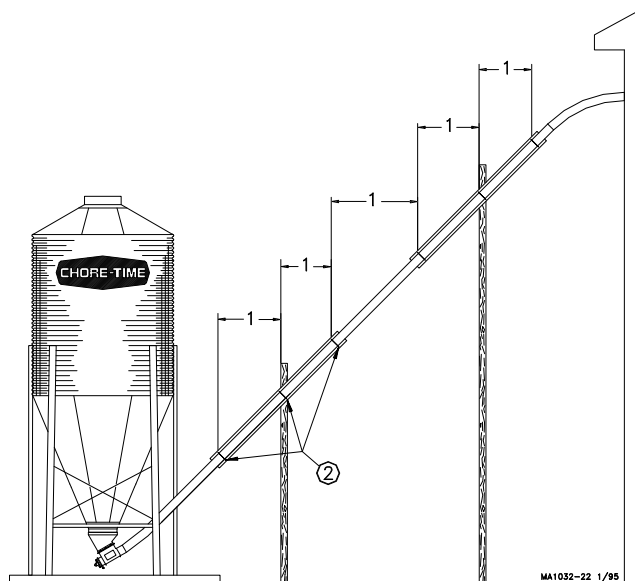

Key	Description
1	5' (1.5 m) for PVC Systems 10' (3 m) for Steel Systems
2	Place clamps here.

Figure 9.High Rise Auger Tube Support

Long, Elevated Systems

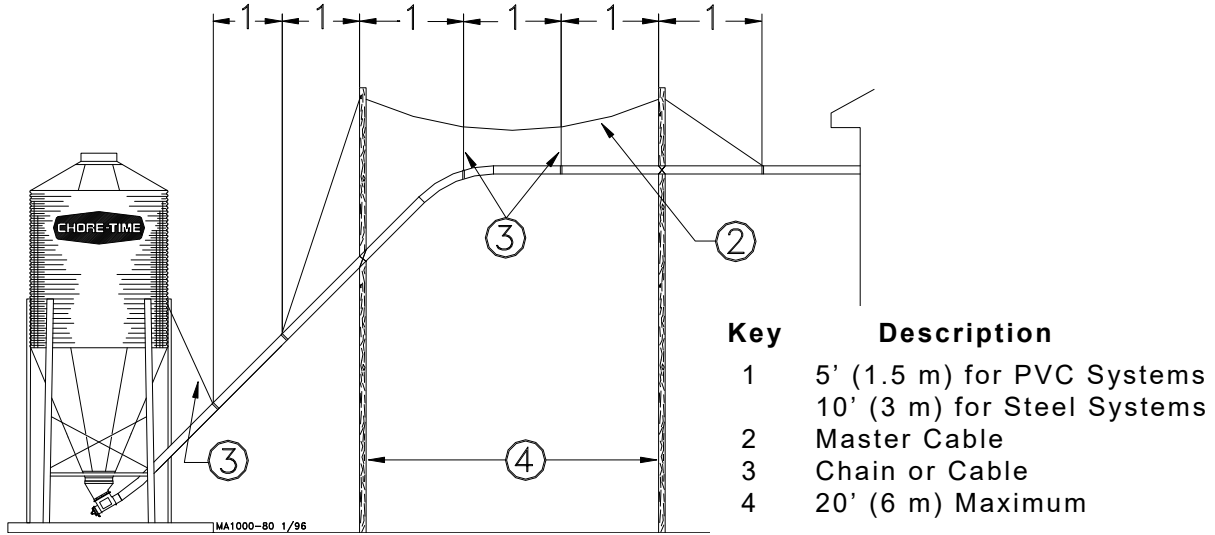

Figure 10. Long, Elevated Systems

Bin to Bin Support System

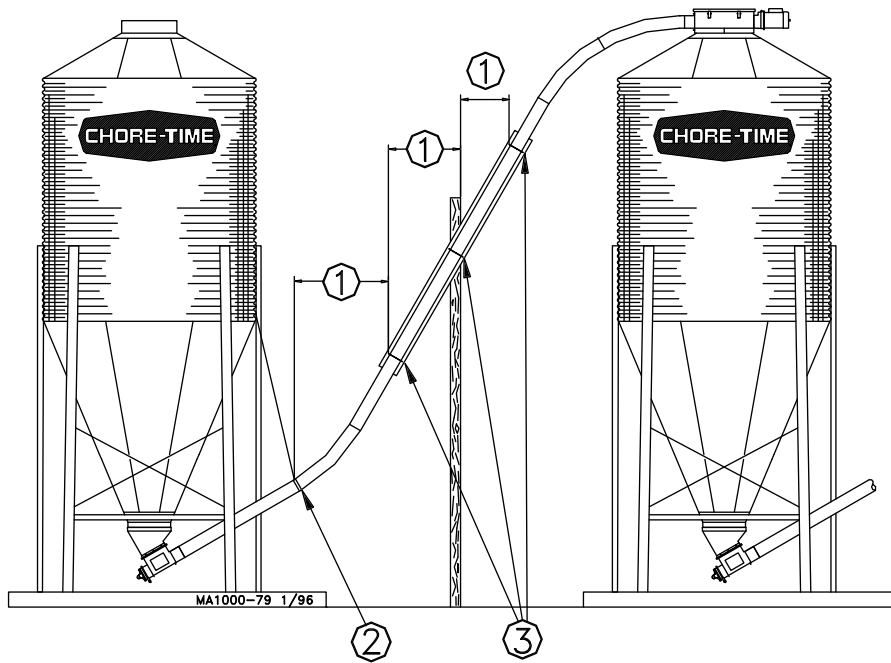
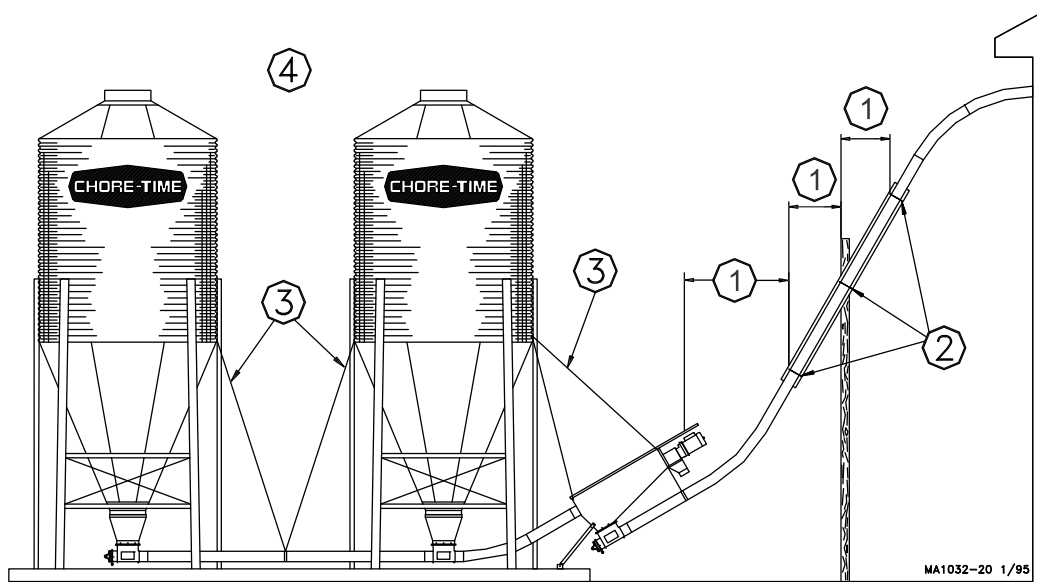

Figure 11. Bin to Bin Support System

Straight Through Tandem Systems



Key	Description
1	5' (1.5 m) for PVC Systems 10' (3 m) for Steel Systems
2	Place clamps here.
3	Chain or Cable
4	Tandem Feed Bins

Figure 12. Straight Through Tandem Systems

Control Unit & Power Unit Installation

1. Attach the tube anchor to the appropriate end (determine the best side of control unit for switch placement) of the control unit body by inserting the 1/4-20x.75 carriage bolts from the inside of the control unit through the tube anchor and attach 1/4-20 flange hex nut.

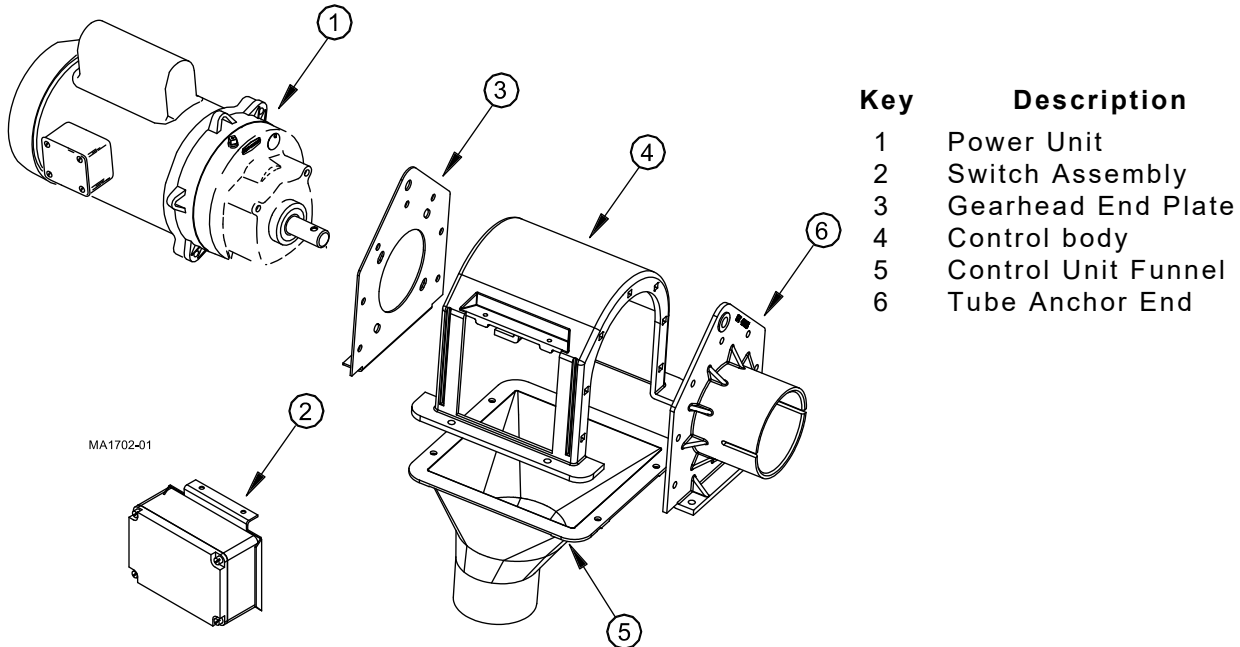

Figure 13. Control Unit/Power Unit Assembly Procedure

2. Connect the power unit to the gearhead end plate using the 5/16-18 machine screws and the flat washers packed with the control.
3. Attach the gearhead end plate to the control unit body the same as the tube anchor.
4. Insert the lower section of the switch assembly into the control unit and secure the top with the 2 #10x.5 screws provided.

For Single Phase Direct Drive Control Units:

Connect the electrical wires on the power unit to the control unit.

- A. Drill bottom of control unit switch box with 7/8" (22.2mm) hole to receive the 90o connector and motor wire. Use caution not to disturb any wires or components of the switch box ass'y when drilling holes.**
- B. Attach the 90 degree connector & conduit to the control unit housing.**
- C. Attach the insulated motor wires to the terminal block in the control housing: one wire to terminal "3" and one wire to terminal "4". Attach the bare grounding wire to one of the green colored screws provided for attaching the grounding wires.**

5. Place the adjustable tube clamp on the tube anchor and connect the control unit/power unit assembly to the end of the FLEX-AUGER® tube.

Note: The switch in the control unit is a safety backup switch in case the hopper level switch or drop tube switch fails to shut off the system. **DO NOT** use the safety switch to control the FLEX-AUGER® System. This will cause feed to bridge in the control.

6. Support the Power Unit and Control Unit securely. Points are provided at the gear head and the tube anchor for suspending the equipment with chain and “S” hooks supplied with the delivery system. See Figure 14.

Note: Other ways of supporting the delivery system can be used where it is practical, as long as the supports do not let the equipment sag or do not make flat spots in the auger tubes.

Note: The motor should be fastened to keep it from twisting. "S" hooks and chain can be attached to the motor base to prevent the motor from shifting.

7. Install the driver assembly on the power unit shaft. Start the socket head screws but leave the anchor clamp loose enough to slip in the auger.

8. Replace the plastic shipping plug in the gear head with the vent plug provided.

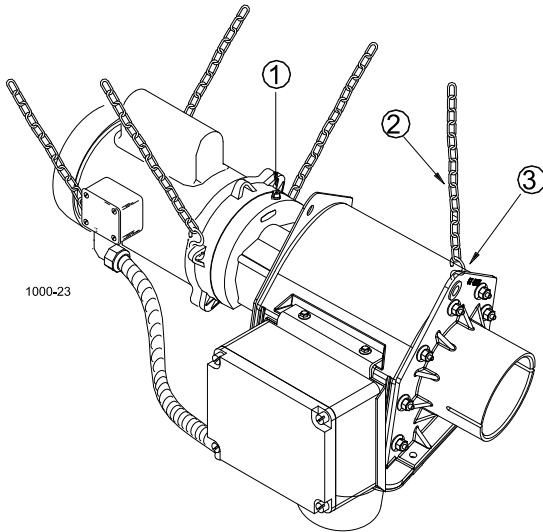

Key	Description
1	Replace the plastic shipping plug with vent plug.
2	Chain
3	“S” Hook

Figure 14. Control Unit/Power Unit Suspension

Note: Other ways of supporting the delivery system can be used where it is practical, as long as the supports do not allow the equipment sag or do not make flat spots in the auger tubes.

Note: Unit must be protected from the elements. Unit as installed is not protected from direct rain or snow.

Belt Drive Control Unit Installation

The Belt Drive Control Unit installation is much the same as the direct drive unit. Mount the Belt Drive Adapter and Motor to the control unit, then proceed with installation to the auger tube as described in this manual. See “**Belt Drive Control Unit (Part No. 46138-2)**” on page 38 for an assembly guide for the Belt Drive Control Unit.

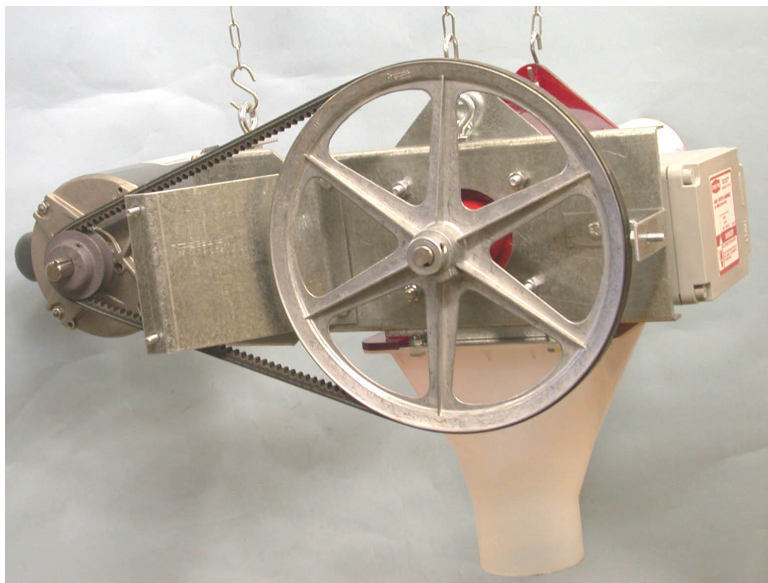

Figure 15. Belt Drive Control Unit. (Belt Guard not installed)

Auger Installation

Use extreme caution when working with the auger. The auger is under tension and may spring causing injury. Always wear protective clothing and protective glasses when working with the auger.

Use extreme caution when pushing the auger into the auger tubes. Keep your hands away from the end of the auger tube to avoid injury.

Handle the FLEX-AUGER® carefully. Dropping the rolls of auger may cause the auger to kink. Do not install an auger that has a sharp kink in it. The kink will cause the auger to wear a hole in the tube at that spot. If the kink cannot be straightened with pliers, the kink must be cut out and the auger brazed back together. Refer to the "Auger Brazing" section in this manual for the correct brazing procedure.

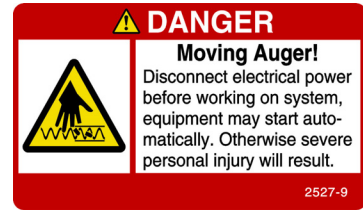

1. Beginning at the boot, push the auger into the auger tube through the rear of the boot until the auger reaches the control unit end of the line.

Use extreme caution when pushing the auger into the auger tubes. Keep your hands away from the end of the Boot to avoid injury.

2. Attach the auger to the Driver Assembly by rotating the driver and threading the auger through the Anchor Clamp.
3. Rotate the auger so that it is fully engaged on the Driver Assembly. Tighten the screws securely to clamp the auger to the Driver Assembly. See **Figure 16**
4. Attach the drop tube and install the slide cover on the control unit.
5. Pull on the loose end of the auger at the boot once or twice until it begins to stretch, then release it slowly. This will bring the auger to its natural length.

Key	Description
1	Model 108 Driver Assembly
2	Anchor Clamp

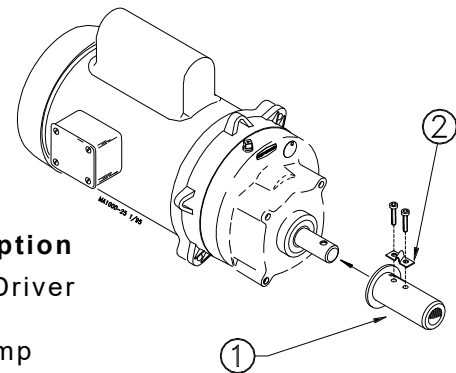

Figure 16. Model 108 Auger Installation (Drive End)

Note: For ease of cutting, measure and mark the auger at the point where it is to be cut. Then, pull the auger an additional 6-8" (150-200 mm) and use locking pliers to clamp the auger while you cut it.

IMPORTANT: Stretch the auger 8 inches (200 mm) for every 50 feet (15.2 m) of length. **Example:** For a 150 ft. (45 m) system the auger should be cut 24 inches (610 mm) shorter than its natural length. Measure the amount of stretch from the rear edge of the boot and cut the auger at that point.

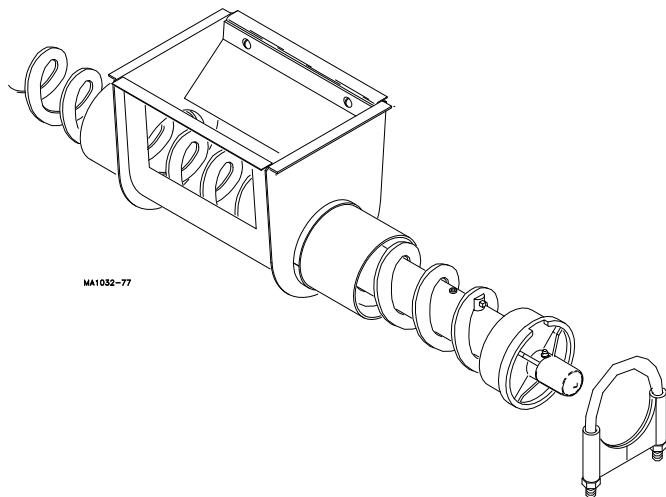

Figure 17. Model 108 Anchor and Bearing Assembly

6. **Figure 17** shows the proper assembly of the Model 108 boot components. Insert the Anchor Shaft into the auger until the auger touches the anchor flange. The auger must be threaded onto the Boot Anchor Assembly, through the clamp pin. Use a 5/16" open-end wrench to tighten the clamp pin setscrew on the auger.
7. **CAREFULLY remove the locking pliers while holding on to the Anchor and Bearing Assembly and auger securely.**
8. **CAREFULLY allow auger to draw the Anchor and Bearing Assembly back into the Lower Boot. DO NOT ALLOW THE BEARING TO BE SLAMMED BACK INTO THE BOOT.**
9. Attach the Anchor and Bearing Assembly to the Boot, using tube clamp provided.

Cover Plate Installation

If the Cover Plate is to be used, install as shown in **Figure 18**.

1. Loosen wing nuts to end of studs
2. Start lower side of cover plate in boot opening.
3. Slide the cover plate up as far as possible so that plate catches top of boot opening.
4. Hold the cover securely while tightening the wing nuts.

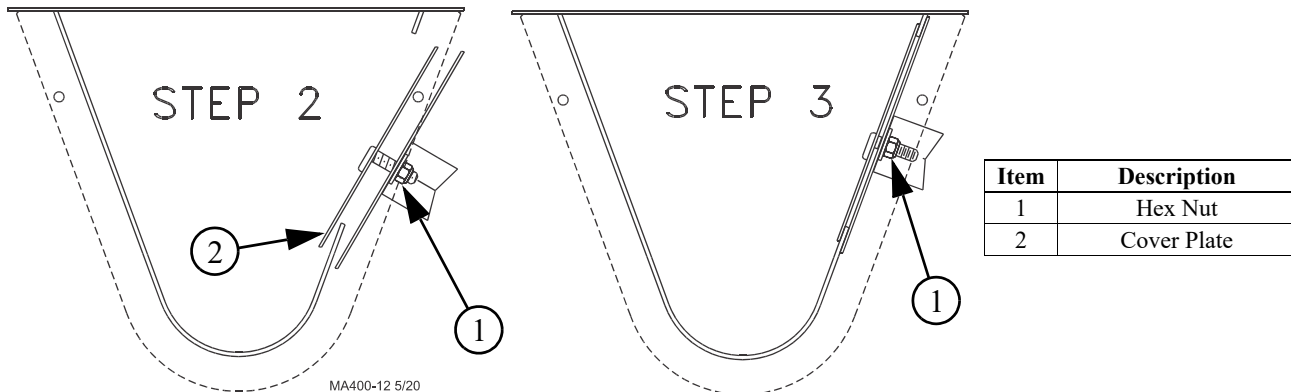

Figure 18. Cover Plate Installation

Auger Brazing/Filing

If the auger needs to be spliced or lengthened, locate the brazed joint closer to the power unit to minimize feed flow restriction in the line.

To align the auger for brazing, lay it in an 18” (46 cm) piece angle iron and clamp securely.

Rotate the auger to allow both the inside and outside edges of the augers to be brazed.

Butt the ends of the auger against each other. **DO NOT SCREW ONE AUGER INSIDE THE OTHER**--This restricts the feed flow.

Lap the augers approximately 2” (50 mm), as shown in **Figure 19**.

A bronze, flux-coated rod is recommended. The joint should be well filled and smooth so that it does not wear against the tube. Allow the joint to air cool.

File the auger edges, as shown in **Figure 19**, to avoid damage to the auger tubes. Also, file off any brazing that extended beyond the outside radius of the auger flightings.

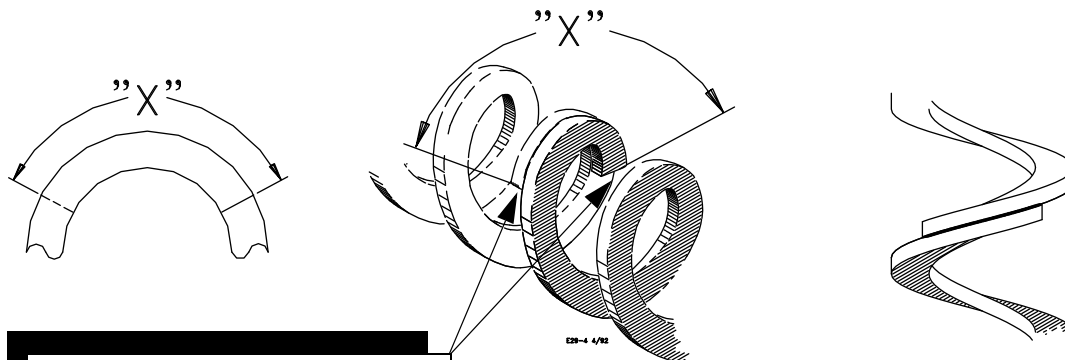

Note: Sharp Auger Ends at the braze(s) must be filed or ground to avoid damage to Auger Tube(s).

Key	Description
X	2” (50 mm)

Figure 19. Auger Brazing/Filing

Restrictor Adjustment

NOTE: The Model 108 feed delivery capacities may be increased by reducing the length of the Restrictor.

DO NOT ADJUST THE RESTRICTOR UNTIL THE SYSTEM HAS BEEN IN OPERATION AND THE SYSTEM IS BROKEN IN.

Note: Feed delivery capacities are based on 40 lbs/ ft.3 (640 kg/m3) feed density. Systems using lighter weight feeds may not be able to achieve the maximum capacities listed.

Note: Always refer to the motor amperage nameplate when increasing the feed flow capacity. Exceeding the nameplate amperage may result in nuisance motor overload tripping and/or damage to the system.

1. Loosen the tube clamp on the back of the Lower Boot to remove the Anchor and Bearing Assembly from the boot.

Note: Use extreme caution when working with the auger under tension. Springing auger can cause personal injury.

2. Pull enough of the auger out of the auger tube to allow the Restrictor Tube to be cut.
3. Use locking pliers to hold the auger outside the boot.
4. Use a hacksaw to cut 1" (25 mm) at a time off the end of the Restrictor Tube to increase feed flow. See **Figure 20**.
5. CAREFULLY remove the locking pliers while holding on to the Anchor and Bearing Assembly and auger securely.
6. CAREFULLY allow the auger to draw the Anchor and Bearing Assembly back into the Lower Boot. DO NOT ALLOW THE BEARING TO BE SLAMMED BACK INTO THE BOOT.

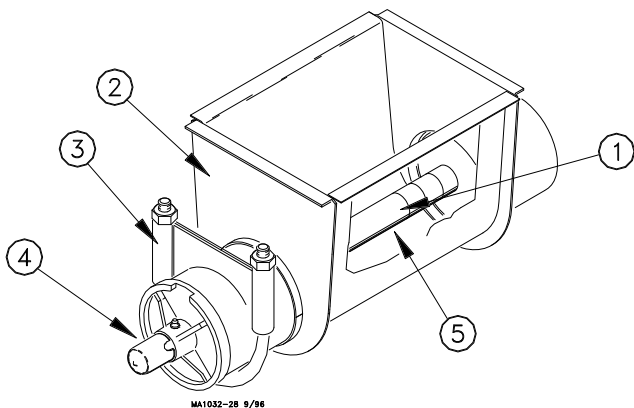
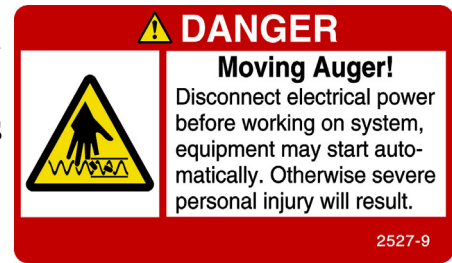

Key	Description
1	Restrictor Tube
2	Lower Boot
3	Tube Clamp
4	Anchor and Bearing Ass'y
5	Cut off approximately 1" (25 mm) of the Restrictor Tube to increase feed flow. Repeat as required.

Figure 20. Anchor and Bearing Installation
(Note: Auger not shown for clarity).

Straight-Through Tandem Boot

The Straight-Through Tandem Boots allow a single auger to remove feed from two separate feed bins. Feed should only be drawn from one bin at a time.

Boot Baffles are required and included with the Straight-Out Boot Assembly.

Model 108 Straight-Through Tandem Systems do not use Feed Restrictors.

1. Install boots on both feed bins. **Figure 21** shows a typical Straight-Through Tandem System.

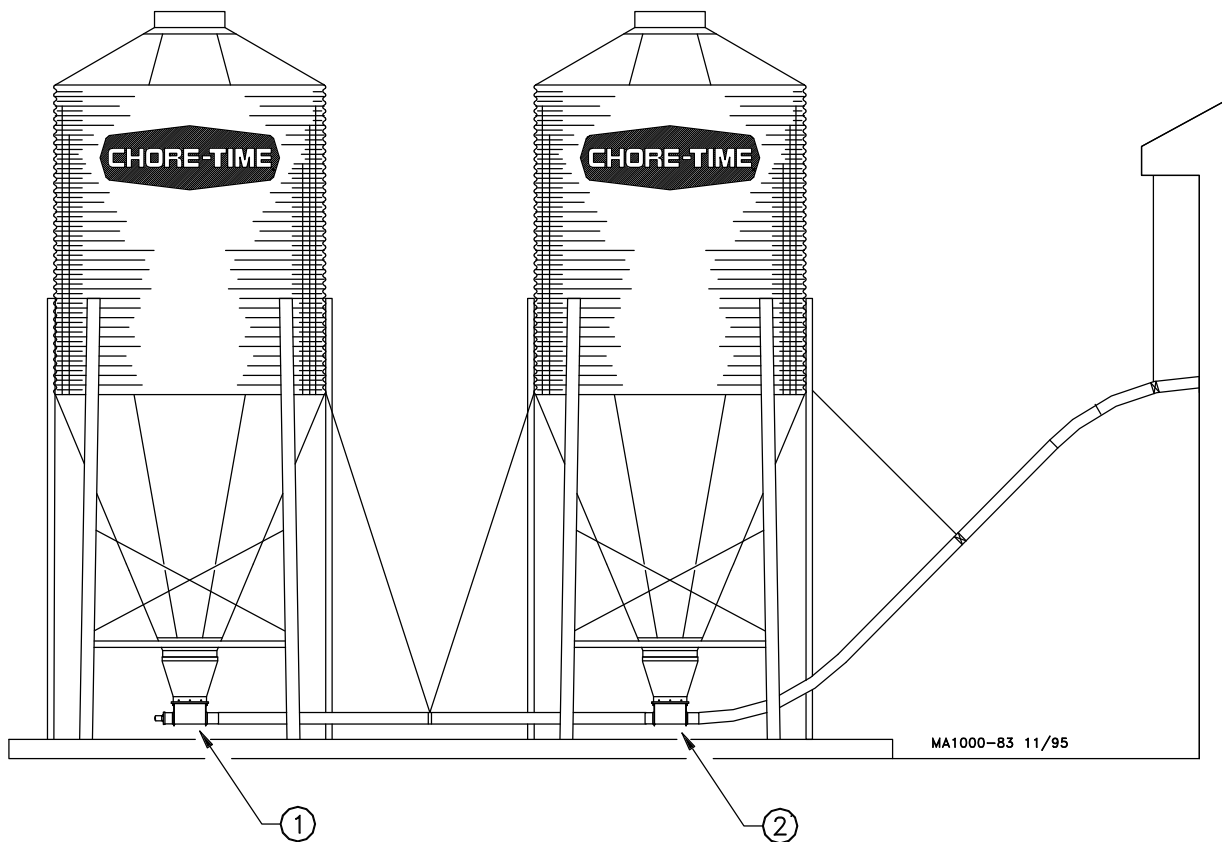

Key	Description
1	Straight-Out Boot on Terminal Bin
2	Straight-Thru Boot (w/Baffle) on Intermediate Bin

Figure 21. Model 108 Straight-Through Tandem

PVC Model 108 FLEX-AUGER® Systems

1. Place an Insert in the belled end of the connecting auger tube. The Insert fits directly over the outlet end of the Terminal Boot.
2. Cut the straight end of the auger tube even with the stub tube on the Intermediate Boot.
Slide an Insert into the end of the auger tube and over the inlet end of the intermediate boot.
3. Secure this joint using a Tube Coupler and clamp.
4. Place an Insert in the belled end of the Elbow before inserting over the outlet end of the Intermediate Boot.
5. Install tube clamps as shown to secure the boot components in place.

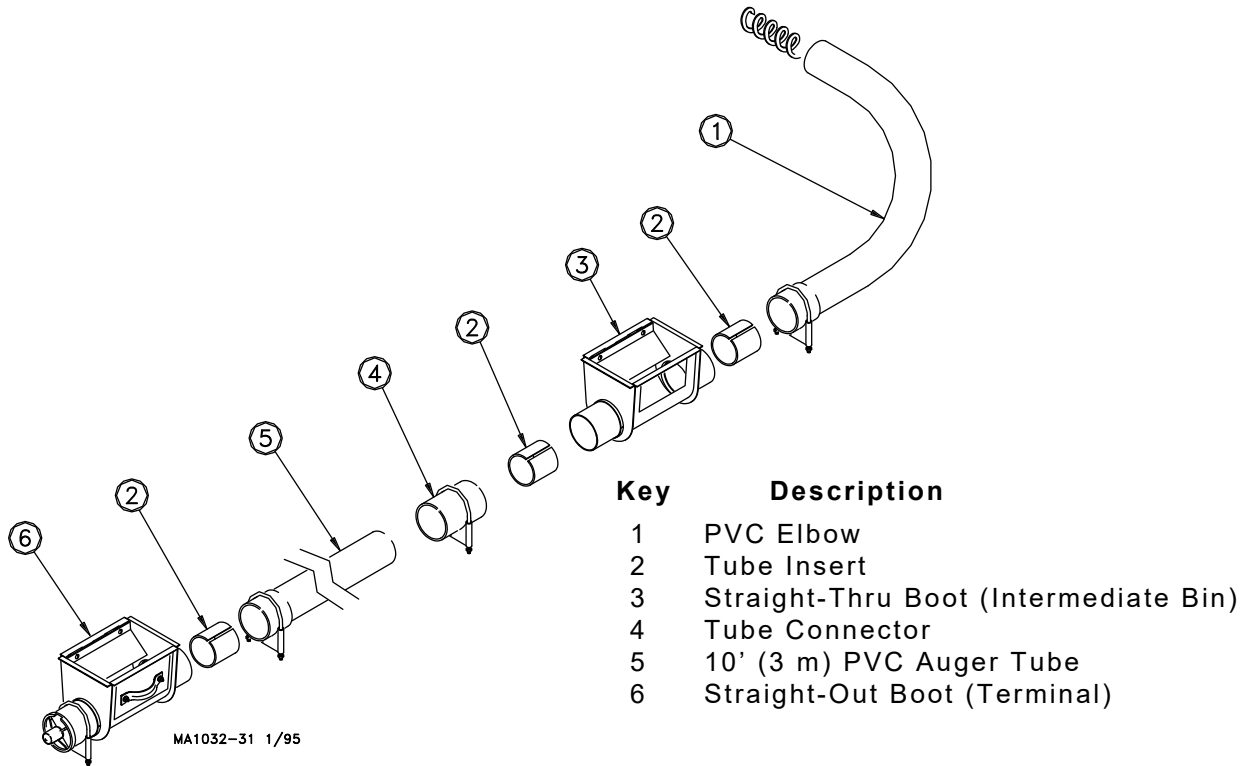

Figure 22. Model 108 PVC Straight-Through Tandem System

Steel Model 108 FLEX-AUGER® Systems.

1. Slide the belled end of the pipe over the outlet end of the Straight-Out Boot.
2. Cut the straight end of the auger tube even with the inlet end of the Intermediate Boot. Secure this joint using a Connector and clamps.
3. Align one end of the Elbow to the outlet end of the Straight-Thru Boot. Secure in place using a Tube Coupler and clamps.
4. Install the remaining auger tubes in the system. Remember to caulk all tube joints exposed to the weather or moisture.
5. Install the auger and Anchor and Bearing Assembly as specified in the installation section of the standard Model 108 FLEX-AUGER® system.

Important: Stretch the auger in the same manner you would for the standard installation except add 16" [406mm] of stretch per 50' [15.2m] and cut it even with the rear of the straight-out boot.

6. Use a tube clamp to secure the bearing to the boot.

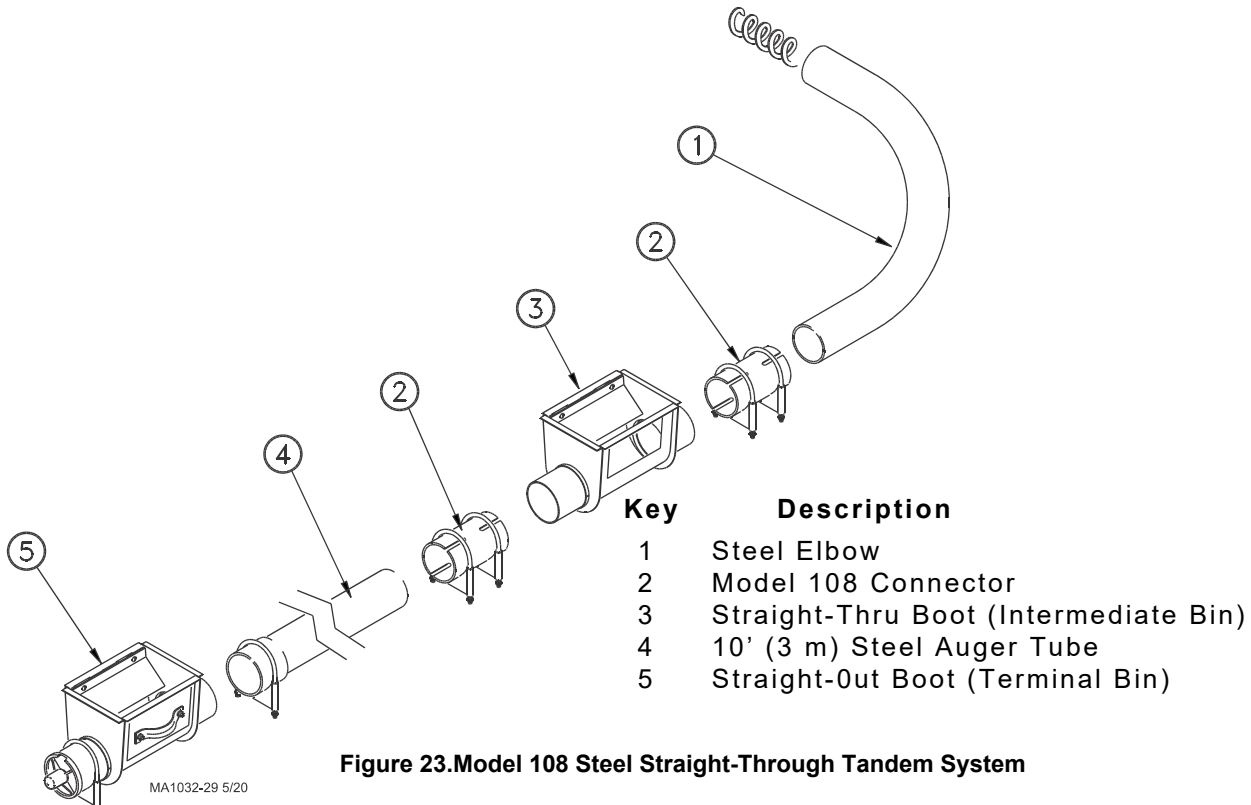

Figure 23. Model 108 Steel Straight-Through Tandem System

Feed Level Control Installation

The Hopper Level Control (or Drop Tube Switch) is installed in the feed hopper (or on the drop tube over the feeder) at the power unit end of the line. This switch stops the FLEX-AUGER® Feed Delivery System when the last feeder is full. Install the hopper level control or drop tube switch according to instructions shipped with the unit. Wire the switch into the system as specified in the appropriate wiring diagram in this manual.

Wiring Diagram for Model 108 System w/Hopper Control Switch (1 H.P. or smaller, Single Phase)

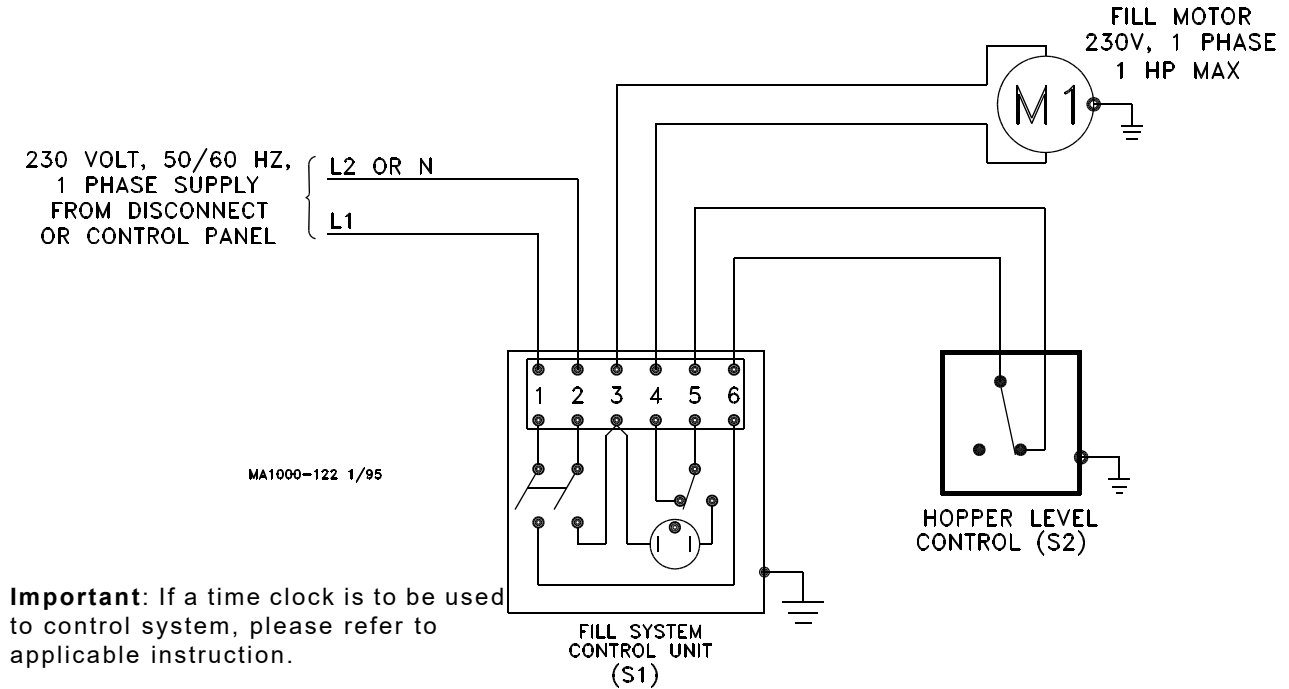
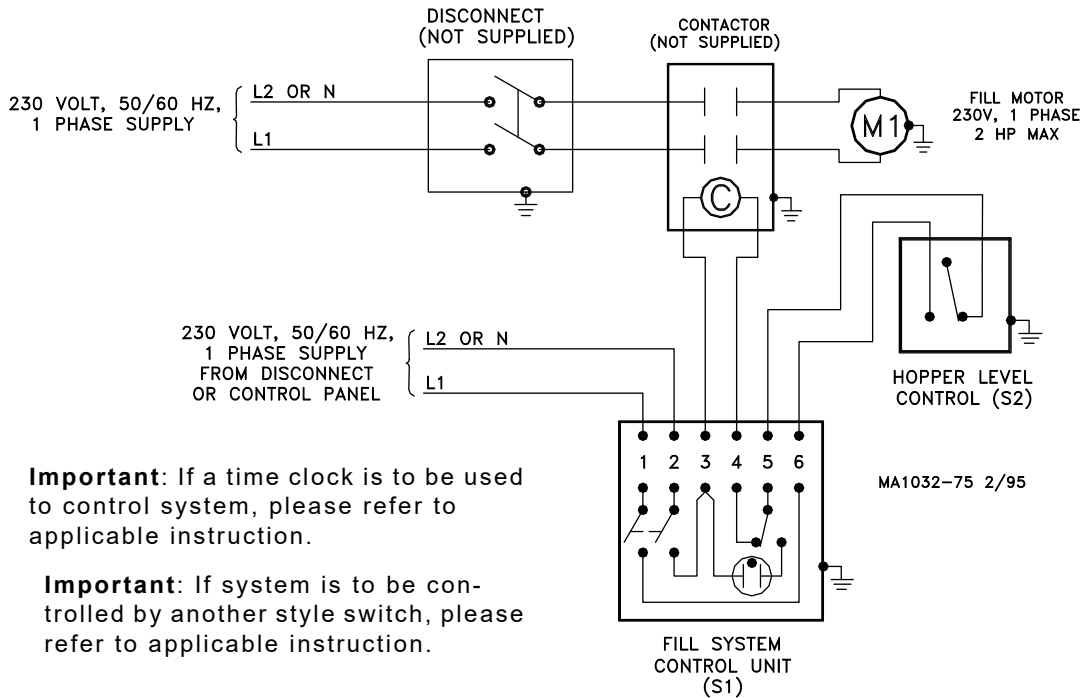

Figure 24. Model 108 (1 H.P. or smaller) Hopper Level Control Switch Wiring Diagram

Wiring Diagram for Model 108 w/Hopper Control Switch (1-1/2 H.P. or larger, 3 Phase)



Important: If a time clock is to be used to control system, please refer to applicable instruction.

Important: If system is to be controlled by another style switch, please refer to applicable instruction.

Figure 25. Model 108 Hopper Level Control Switch (1-1/2 HP or larger) Wiring Diagram

Wiring Diagram for Model 108 w/Hopper Control Switch

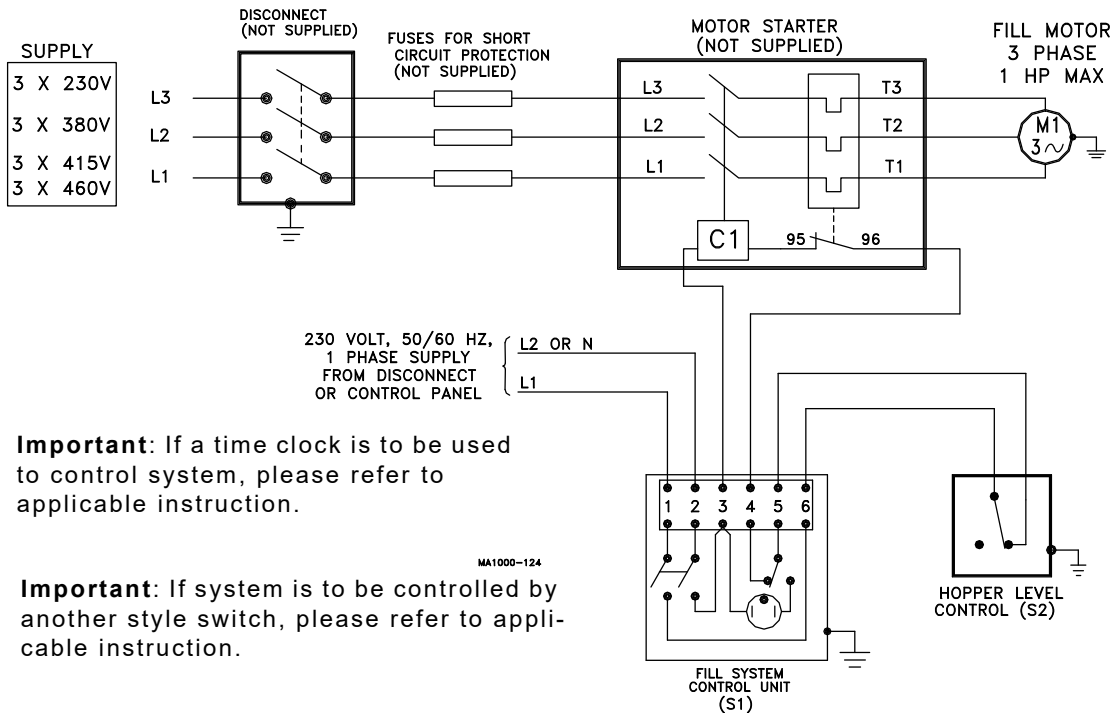

Important: If a time clock is to be used to control system, please refer to applicable instruction.

Important: If system is to be controlled by another style switch, please refer to applicable instruction.

Figure 26. Model 108 Hopper Level Control Switch Wiring Diagram

Operation

1. During initial start-up, the boot slide should be only partially open to prevent the full length of auger from being charged with feed. After that, the boot slide must be fully open for delivery system operation.
2. Do not permit the FLEX-AUGER® system to operate empty. Use a time clock or Auger Timer with the system whenever possible. This reduces short cycling by operating on a preset schedule instead of on demand. It also prevents excessive running of the system if the bin becomes empty. If the optional boot switch is used, the fill system will shut down when the bin becomes empty.
3. Program the time clock to fill feeders often so the FLEX-AUGER® System does not have to run a long period of time to get feeders filled. Poultry feeders supplied by the FLEX-AUGER® System should be operated by a time clock so feeders start at the same time. This gives the FLEX-AUGER® System a better chance to keep up with them.

Note: The hopper level control must be positioned low in the last feeder hopper.

4. The red light on the control unit will light if feed has packed inside. If this happens, remove feed from the drop tube and tap the side of the power unit to clear the safety switch. Keep the hopper level control in adjustment and positioned straight up and down so the paddle swings freely. The safety switch does not take the place of the hopper level control.
5. If the FLEX-AUGER® System must be used to convey high-moisture feed, empty the auger line completely after each running to prevent the feed from setting up in the tubes.
6. The Restrictor in the boot regulates the amount of feed flowing into the auger. Start a new system with the Restrictor installed as shipped--full length and flush with the front of the boot. Allow the system to polish out before adjusting the feed flow. Maximum restriction for the boots results when the restrictor is in this position. If more feed flow is desirable, the restrictor may be shortened. Refer to the section “**Restrictor Adjustment**” on page 26.
7. When operating the Straight-Through Tandem System, open the slide on only one bin at a time!
8. Model 108 High-Moisture Corn Applications only: Chore-Time recommends purging the system after the last feeding each day. Do not allow feed to set in the tubes for more than 24 hours. Additionally, do not allow the charged system to set idle in freezing conditions for extended periods of time.

Start-Up Procedure for New Systems

Important! DO NOT RUN FEED THROUGH A NEW SYSTEM UNTIL AFTER THIS PROCEDURE HAS BEEN FOLLOWED OR THE AUGER WILL PLUG AND BIND.

1. Close the Slide on the FLEX-AUGER® Boot.
2. Operate the system empty for one minute.
3. Open the slide on the FLEX-AUGER® boot no more than 1 inch (25 mm) to allow some feed into the boot.
4. Operate the system with the slide in this position until feed has reached the Control Unit. This removes the manufacturing grease and oil from the auger and tubes. If this grease and oil is not removed, the feed may bunch up causing the auger to plug and bind.
5. Now the slide can be fully opened and the system operated normally.

Parts Listing

Miscellaneous Line Components

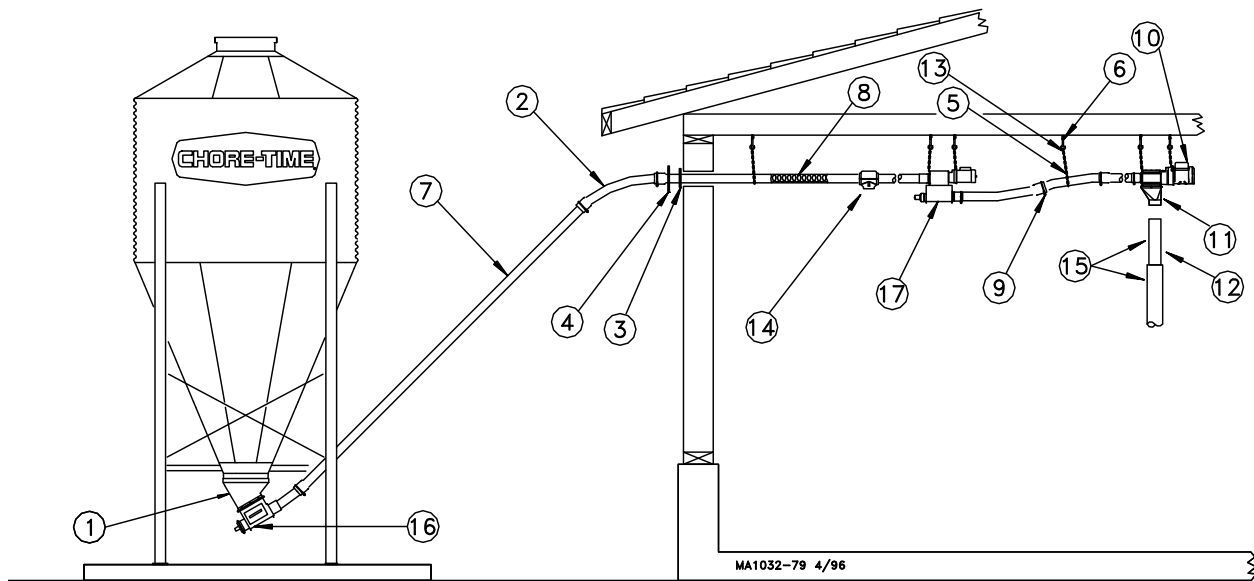

KEY	DESCRIPTION	PART NO.
1	Upper Boot (30 Degree)	4347R/C
	Upper Boot (Straight-Out)	6093R/C
2	PVC Elbow, 45 Degree	34546
	--Optional 45 Degree Hard. Steel Elbow	34406
3	Neoprene Seal	34334
4	Seal Ring	8117
5	Chain	2128-100
6	Screw Hook	1214
7	10' (3 m) PVC Tube	34547
	10' (3 m) Steel Tube	34411
8**	Model 108 Auger	30108-0
9	Tube Clamp (for PVC systems)	14373
	Tube Clamp (for steel systems)	34338
10	Power Unit	See Individual Part Lists
11	Control Unit (Direct Drive)	46800-5
	Control Unit (Belt Drive)	46800-15
	Control Unit (Direct Drive, 3 Phs)	46800-10
12	Plastic Drop Tube	9900
13	S Hook	2805
14	Outlet Drop	34358
15	Telescoping Drop Tube	14366-9900
16	Lower Boot Assembly (30 Degree)	34336
	Lower Boot Assembly (Straight-Out)	34341
17	Extension Boot Kit	47862-0
--	Connector w/clamps (for steel systems)	34419
--	Connector (for steel systems)	30277
--	Tube Connector (for PVC systems)	34557

**Auger may be ordered in lengths from 20 ft. to 200 ft.
Ex. 30108-155 would be 155' of auger.

Model 108 Drop Kit (34358)

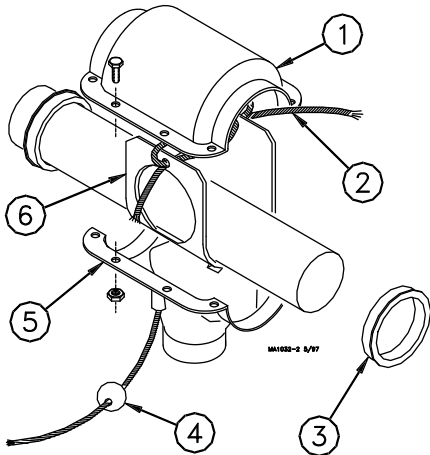

KEY	DESCRIPTION	PART NO.
1	Drop Half (top)	13780
2	.150 Dia. Rope	3085
3	Ring Adapter (for PVC systems)	34630
	Ring Adapter (for STEEL systems)	34360
4	Indicator Ball (red)	24393-1
	Indicator Ball (green)	24393-2
5	Drop Half (bottom)	13781
6	Rotary Slide	34359

Power Unit Assembly Part Numbers

Part Number	HP	RPM	Phase	Hz	Voltage
3259-49	1 HP	348 RPM	Single Phase	60 Hz	230
3259-52	3/4 HP	348 RPM	Single Phase	60 Hz	230
3259-66	1-1/2 HP	348 RPM	Single Phase	60 Hz	230
3259-79	1 HP	425 RPM	Single Phase	60 Hz	230
3259-80	1-1/2 HP	425 RPM	Single Phase	60 Hz	230
3259-121	2 HP	425 RPM	Single Phase	60 Hz	230
3259-88	3/4 HP	348 RPM	Single Phase	50 Hz	230
3259-89	1 HP	348 RPM	Single Phase	50 Hz	230
3259-50	1/2 HP	216 RPM	Single Phase	60 Hz	230
3259-136	3/4 HP	216 RPM	Single Phase	60 Hz	230
3259-105	1 HP	348 RPM	Three Phase	50 Hz	220/380
3259-106	1-1/2 HP	348 RPM	Three Phase	50 Hz	220/380
3259-104	3/4 HP	348 RPM	Three Phase	50 Hz	220/380
3259-117	1.0 HP	348 RPM	Three Phase	60 Hz	208-230/460
3259-118	1.0 HP	425 RPM	Three Phase	60 Hz	208-230-460
3259-119	3/4 HP	348 RPM	Three Phase	60 Hz	208-230/460
3259-139	1.5 HP	348 RPM	Three Phase	60 Hz	208-230/460
3259-140	1.5 HP	425 RPM	Three Phase	60 Hz	208-230/460
3259-170	2 HP	425 RPM	Three Phase	60 Hz	208-230/460

Power Units

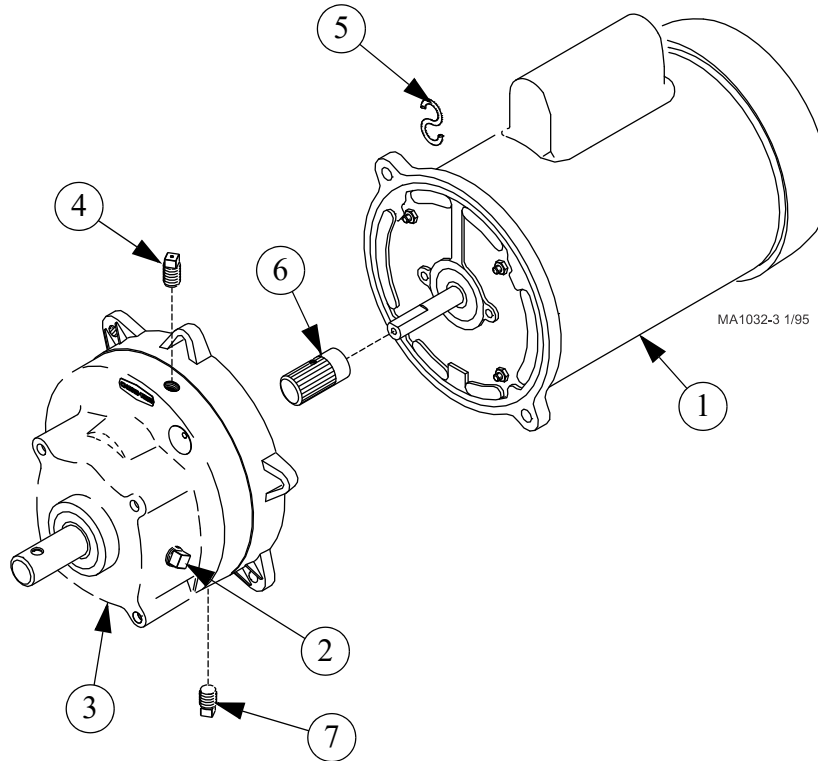

Item	Description	3259-49 Part No.	3259-52 Part No.	3259-66 Part No.	3259-79 Part No.	3259-80 Part No.	3259-121 Part No.
1	Motor	6857	5051	8782	6857	8782	34461
2	Pipe Plug	2755	2755	2755	2755	2755	2755
3	Gearhead	3261-7	3261-7	3261-7	3261-10	3261-10	3261-10
4	Vent Plug	3523	3523	3523	3523	3523	3523
5	S Hook	2805	2805	2805	2805	2805	2805
6	Pinion Assembly	6104	5046	6104	6104	6104	6104
7	Magnetic Pipe Plug	30160	30160	30160	30160	30160	30160

Item	Description	3259-88 Part No.	3259-89 Part No.	3259-105 Part No.	3259-106 Part No.	3259-50 Part No.	3259-104 Part No.
1	Motor	6305	26157	28035EUR	28036EUR	5050	28034EUR
2	Pipe Plug	2755	2755	2755	2755	2755	2755
3	Gearhead	3261-10	3261-10	3261-10	3261-10	3261-6	3261-10
4	Vent Plug	3523	3523	3523	3523	3523	2523
5	S Hook	2805	2805	2805	2805	2805	2805
6	Pinion Assembly	5046	6104	6104	6104	3245	5052
7	Magnetic Pipe Plug	30160	30160	30160	30160	30160	30160

Item	Description	3259-117 Part No.	3259-118 Part No.	3259-119 Part No.	3259-136 Part No.	3259-139 Part No.	3259-140 Part No.	3259-170 Part No.
1	Motor	34101	34101	34102	5051	39589	39589	56218
2	Pipe Plug	2755	2755	2755	2755	2755	2755	2755
3	Gearhead	3261-7	3261-10	3261-7	3261-6	3261-7	3261-10	3261-10
4	Vent Plug	3523	3523	3523	3523	3523	3523	3516
5	S Hook	2805	2805	2805	2805	2805	2805	2805
6	Pinion Assembly	6106	6106	5052	3245	6106	6106	6106
7	Magnetic Pipe Plug	30160	30160	30160	30160	30160	30160	30160

Single Phase Direct Drive Control Unit (Part No. 46800-5)

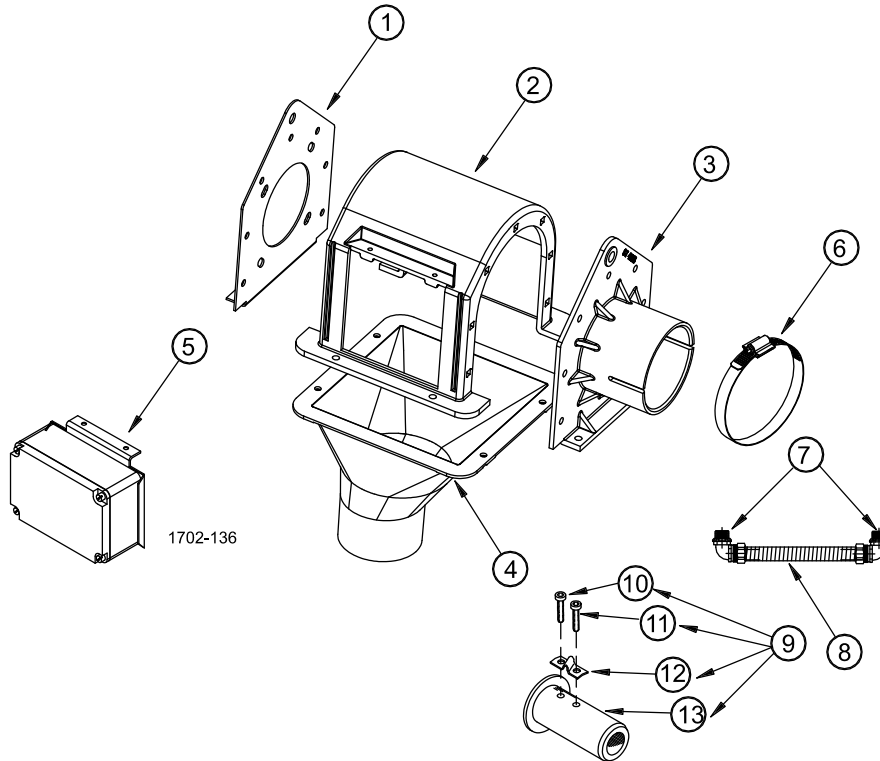

KEY	DESCRIPTION	PART NO.
1	Gearhead End Plate	43596
2	Control Unit Body	43601
3	Tube Anchor Plate	45927
4	Control Unit Funnel	45943-3
5	Switch & Plate Assembly	46051
6	H.D. Adjustable Clamp	47652-2
7	Water Tight Connector	23810
8	Flex Conduit	26982-10
9	Driver Assembly	30313
10	Screw, SKTH CP 5/16-18X .875	6850-1
11	Screw, SKTH CP 5/16-18X 2.75	6850-2
12	Anchor Clamp	7703
13	Driver Weldment	30312

3-Phase International Direct Drive Control Units (Part No. 46800-10)

Components - Same as Standard Direct Drive Control Units except does not include the 90° connectors and the flex conduit.

Switch Plate & Assembly (Part No. 46051)

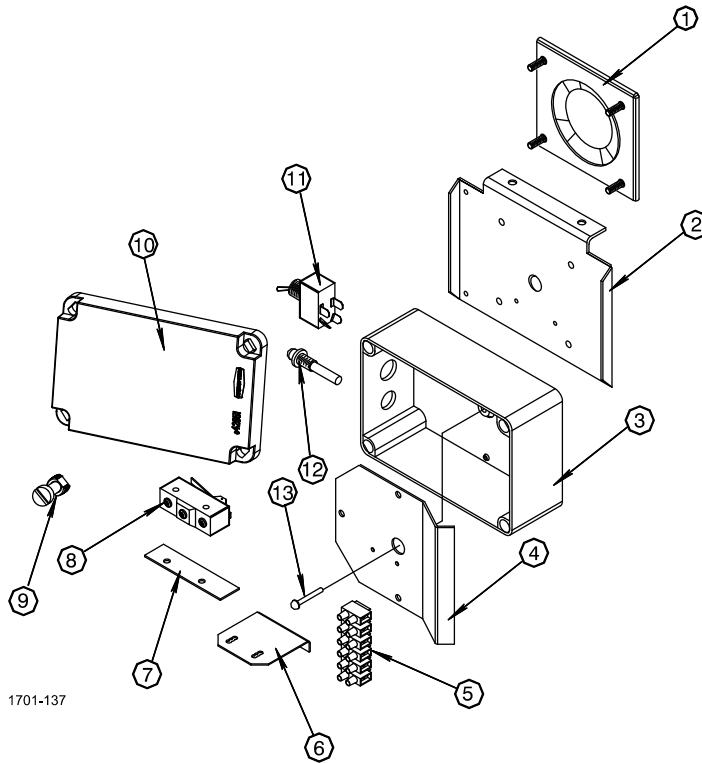

<u>KEY</u>	<u>DESCRIPTION</u>	<u>PART NO.</u>
1	Diaphragm Assembly	46159
2	Switch Cover Plate	46030
3	4x6 Electrical Box	46070-1
4	Mount Panel	46072
5	Terminal Block	34925-6
6	Switch Bracket	46093
7	Switch Insulation	1907-5
8	Micro Switch	46091
9	Plastic Screw	42849
10	4x6 Elect Box Cover	42851
11	Toggle Switch	7767
12	Pilot Light	46047
13	Rivet, 3/16 x 1.00 round Head(S.S.)	46905

Belt Drive Control Unit (Part No. 46138-2)

Note: The 46800-15 Belt Drive Control Unit includes the Direct Drive Control Unit Components, plus the following components:

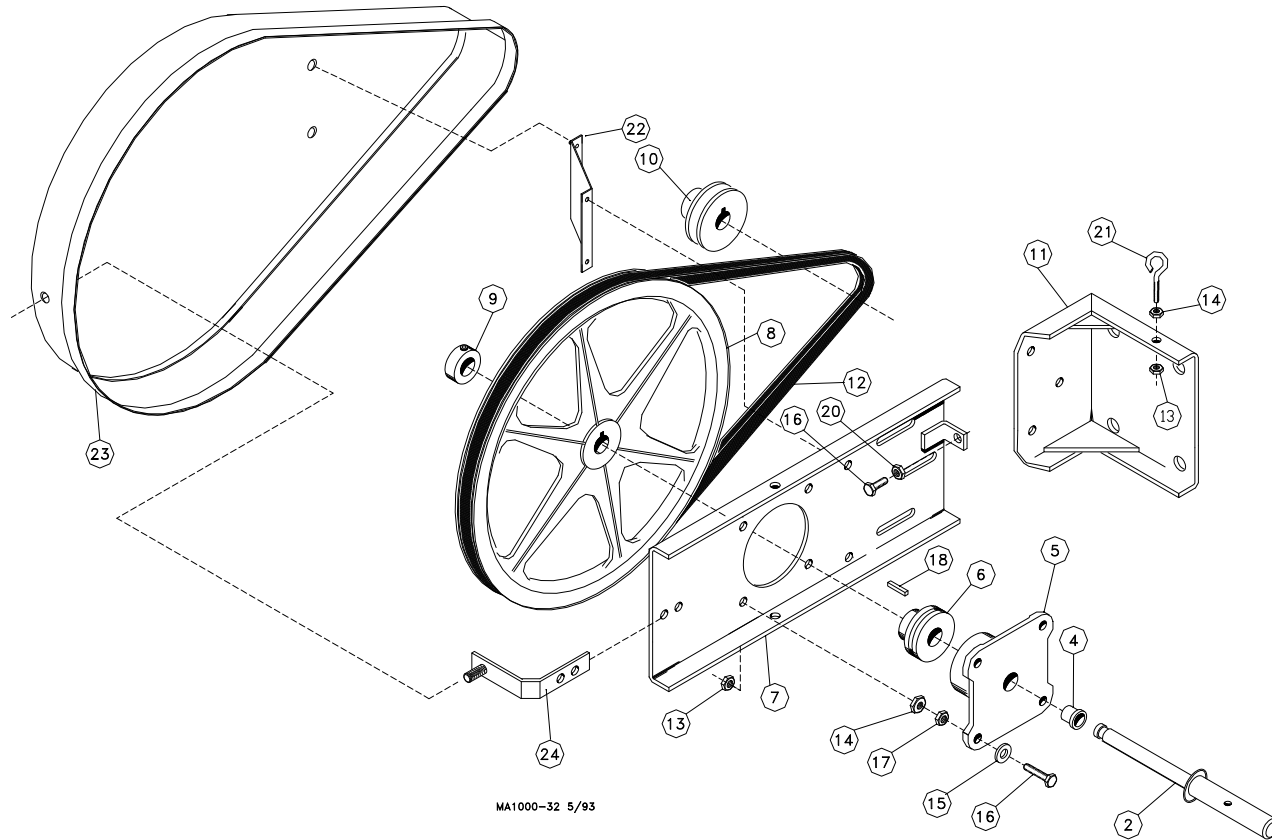

MA1000-32 5/93

Key	Description	Part No.
2*	Drive Shaft	46156
4*	Flange Bearing	2196
5*	Front Plate Bearing Holder	2047
6*	Ball Bearing	5930
7	Adjustment Bracket	46301
8	11" Dia. Sheave	46190
9*	5/8" Set Collar	1386
10	2.25" Dia. Sheave	3208
11	Motor Mount Weldment	3058
12	"V" Gripnotch Belt	4409
13	5/16-18 Hex Locknut	2148

Key	Description	Part No.
14	5/16-18 Jam Nut	593
15	5/16 Flat Washer	546
16	5/16-18x1-3/4" Hex Hd. M.S.	4412-4
17	5/16-18 Hex Lock Nut	2148
18*	3/16" Key	2112-1
19	Anchor Clamp	7703
20	5/16-18 Hex Nut	2145
21	Eyebolt	1503-2
22	Belt guard Mount	46198
23	Belt Guard	46199
24	Angle Guard Mount	46299

*Item May be ordered as a Bearing & Shaft Assembly (Part No. 46157)

Model 108 Boot Components

The Item numbers below are associated with the following two pages.

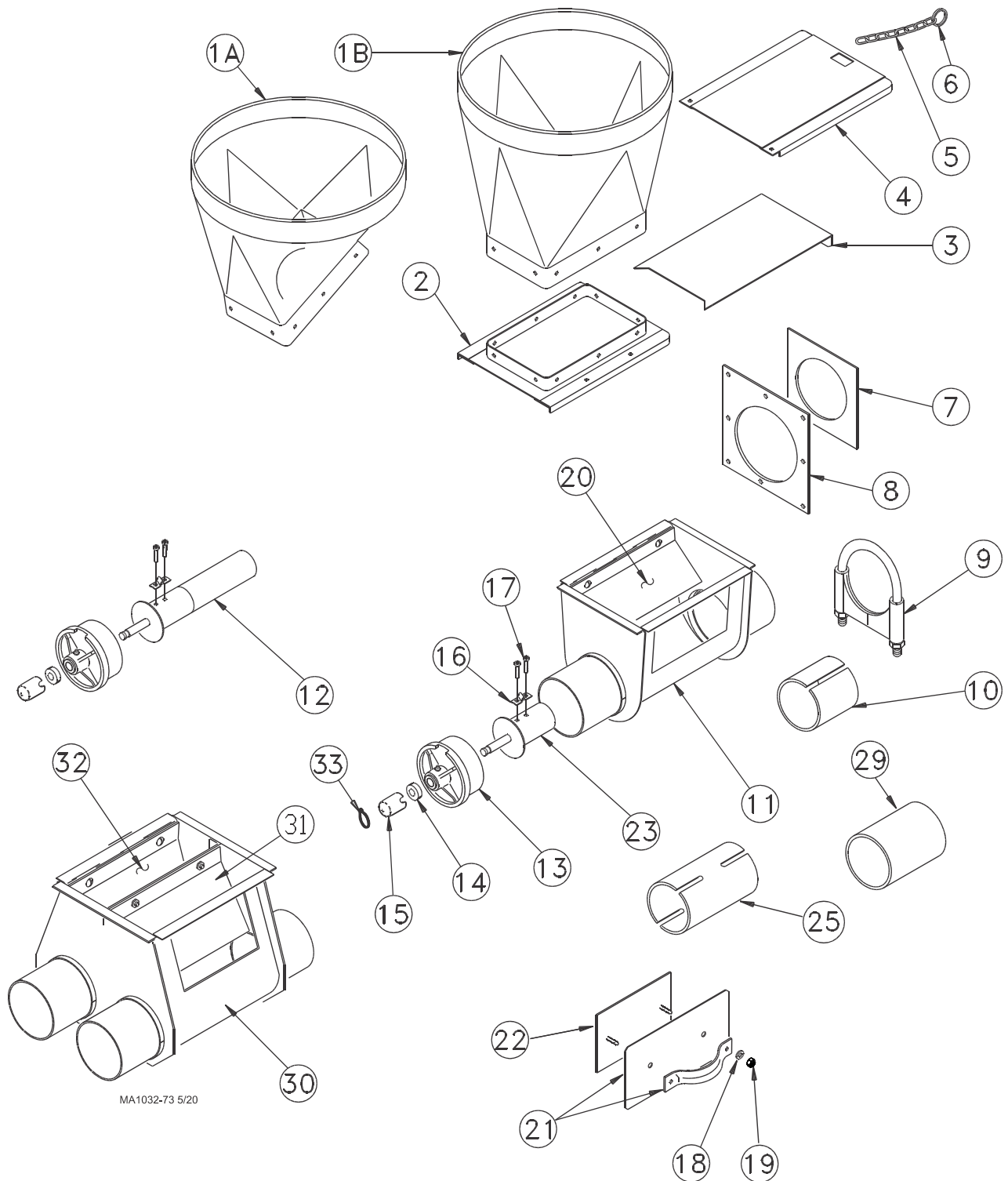

MA1032-73 5/20

Model 108 Boot Components

The Item numbers below are associated with the parts list drawing on the following page.

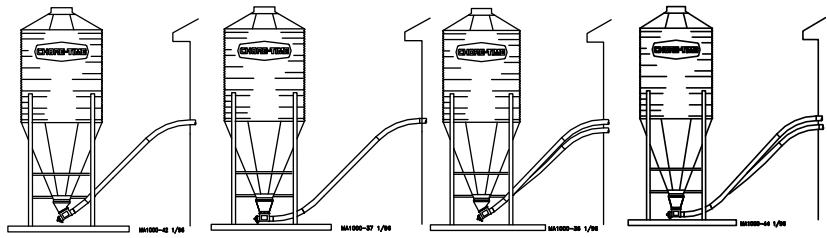

Item	Description	30 Degree Boot System	Straight Out Single Boot Syst.	30 Degree Twin Boot Syst.	Straight Out Twin Boot System
--	Complete System	34339	34340	35625	35626
-- ²	Lower Boot Assembly	34336	34341	35613	35612
1A	30 Degree Upper Boot	4347R/C	----	4347R/C	----
1B	Straight Out Upper Boot	----	6093R/C	----	6093R/C
2	Transfer Plate Assembly	4925	4925	4925	4925
3	Slide	4357	4357	4357	4357
4	Slide Shield	4876	4876	4876	4876
5	Chain	2128-250	2128-250	2128-250	2128-250
6	Ring	1706	1706	1706	1706
7	Neoprene Seal	34334	34334	34334	34334
8	Seal Ring	8117	8117	8117	8117
9	Tube Clamp (for STEEL systems)	34338	34338	34338	34338
9 ³	Tube Clamp (for PVC systems)	14373	14373	14373	14373
10	Tube Insert	34337	34337	34337	34337
11	Boot Body Weldment	30386	30385	----	----
12 ⁵	Anchor Weldment	30311	----	30311	----
13 ⁵	Bearing Cap Assembly	30314	30314	30314	30314
14 ⁵	5/8" Set Collar	1386	1386	1386	1386
15 ⁵	Safety Cap	29702	29702	29702	29702
16 ⁵	Anchor Clamp	7703	7703	7703	7703
17 ⁵	5/16-18 x 7/8 Soc.Hd Cap Screw	6850-1	6850-1	6850-1	6850-1
18 ¹	Sealing Washer	39-20155	39-20155	39-20155	39-20155
19 ¹	5/16-18 Lock Nut	2148	2148	2148	2148
20	Baffle	----	14239	----	----
21 ¹	Cover Weldment	6301	6301	6301	6301
22 ¹	Back Plate Assembly	6298	6298	6298	6298
23 ⁵	Anchor Weldment	----	34369	----	34369
25 ^{4,3}	Model 108 Connector	30277	30277	30277	30277
29 ³	Tube Connector (for PVC systems)	34557	34557	34557	34557
30	Twin Boot Body Weldment	----	----	35617	35617
31	Center Baffle Plate	---	----	----	35624
32	Baffle Weldment	----	----	----	35615
33	Cable Tie	56705	56705	56705	56705

¹These components may be ordered under Chore-Time Part No. 6197 Clean-Out Cover Assembly.

²Items 2 through 32 make up the Lower Boot Assemblies.

³These items are not included in the package and must be ordered separately.

⁴The Model 108 Connector may be ordered with (2) 34338 Tube Clamps under Chore-Time Part No. 34419 Connector w/Clamps.

⁵Items 12 - 17 may be ordered as an Anchor & Bearing Assembly (Restricted) under Chore-Time Part No. 35767. Items 13 - 17 and item 23 may be ordered as an Anchor & Bearing Assembly (Unrestricted) under Chore-Time Part No. 35766.

Model 108 Boot Components (Continued)

The Item numbers below are associated with the parts list drawing on the next page.

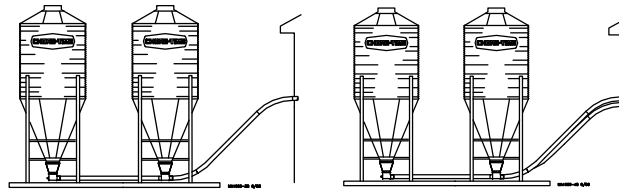

Item	Description	Single Boot System	Twin Boot System
--	Complete System	34333	35616
-- ¹	Straight-Out Lower Boot Assembly	34341	35612
-- ²	Straight-Thru Lower Boot Assembly	34335	35611
1B	Straight Out Upper Boot	6093R/C	6093R/C
2	Transfer Plate Assembly	4925	4925
3	Slide	4357	4357
4	Slide Shield	4876	4876
5	Chain	2128-250	2128-250
6	Ring	1706	1706
10	Tube Insert	34337	34337
11	Boot Body Weldment	30385	----
18 ³	Sealing Washer	39-20155	39-20155
19 ³	5/16-18 Lock Nut	2148	2148
20	Baffle	14239	----
21 ³	Cover Weldment	6301	6301
22 ³	Back Plate Assembly	6298	6294
30	Twin Boot Weldment	----	35617
31	Center Baffle Plate	---	35624
32	Baffle Weldment	----	35615

¹Refer to the Straight-Out Boot Systems on the previous page for miscellaneous Straight-Out Lower Boot Assembly components.

²Items 2 through 32, as listed above, make up the Straight-Thru Lower Boot Assemblies.

³These items may be ordered as an assembly under Chore-Time Part No. 6197.

Troubleshooting

ALWAYS DISCONNECT POWER TO THE SYSTEM WHEN SERVICING OR MAINTAINING THE EQUIPMENT. FAILURE TO DISCONNECT POWER MAY CAUSE INJURY OR DEATH.

Service and maintenance work should be done by a qualified technician only.

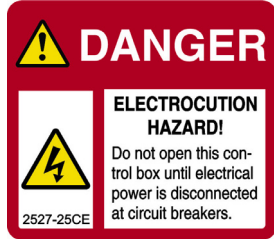

Problem	Possible Cause	Corrective Action
Delivery system will not run.	No power to the system.	Check circuits, fuses, and on-off switches on the equipment.
	Bin level switch has stopped the system due to lack of feed in the boot.	Check feed supply and for possible bridging.
	Motor overloaded and stopped.	Check for foreign material in the line. Push the motor reset button.
	Safety switch actuated in the Control Unit (red pilot light will be lit).	Determine reason for feed packing in the Control Unit. Feed level switch out of adjustment?
Motor overloads after running briefly.	Motor too small.	Use recommended size motor for line length.
	Low voltage (motor runs slow and overheats).	Check line voltage at the motor; use adequate size wire in circuits.
	Foreign object in the auger (motor runs, stalls, then auger spins in reverse).	Check auger line, pull auger to remove objects.
	Motor wired in reverse (motor runs, stalls, no feed conveyed).	Disconnect power and change wire connections (direct drive power unit shaft at rear of motor turns clockwise).
	Boot Anchor tight.	Check for Anchor binding.
	Wet feed being conveyed or allowed to stand in auger tubes. Defective motor (overheats without load).	Clean auger and tubes; avoid conveying wet feed or empty line after each feeding. Replace motor.

Problem	Possible Cause	Corrective Action
Motor runs, but auger does not turn.	Sheared driver bolt at Control Unit.	Replace driver bolt.
	Broken power unit pinion.	Examine pinion on motor shaft; replace BOTH gear head and pinion in pinion is damaged.
Auger wears holes in tubes.	Auger kinked or poorly brazed.	See Auger Brazing section in this manual
Elbows wear out.	Auger is stretched too tight; horizontal L.H. turn; auger has been run dry.	Lengthen auger; Install an Extension Hopper; wire Boot Switch into system.
Excessive auger vibration and noise.	System has been operated too often without feed (auger has scored the auger tubes).	Wire a Boot Switch to stop the system when the feed bin is empty; replace damaged auger tubes; be sure auger has proper amount of stretch.
	Tubes inadequately supported.	Support the tubes every 5' (1.5 m) or closer.
	Horizontal L.H. turn.	No outlet drops on or just before an elbow; lengthen the auger; install an Extension Hopper ahead of elbows.
Fill system short cycles.	Control end feed level switch does not provide large enough feed differential.	Use a time clock to program operating cycles. Use Control end feed level switch w/lock-out and time clock.
Extension Boot packs full of feed.	Too much Restrictor in the Boot.	Shorten Restrictor.
Second portion of extended length system will not start.	Feed level control at end of line out of adjustment.	Examine and make necessary adjustments; see feed level switch adjustment instruction.
Second portion of extended length system short cycles.	Too much Restrictor in the Boot.	Shorten Restrictor.
	Too much feed is still dispensing from drops ahead of Extension Boot. Trim Restrictor on first portion to allow more incoming feed.	Last outlet drop before Extension Boot must have full feed drop out. NOTE: All feeders ahead of Extension Boot must complete filling before feed reaches hopper.

Maintenance

The FLEX-AUGER® Feed Delivery System requires minimum maintenance. However, a routine periodic inspection of the equipment will prevent unnecessary problems.

Maintenance should be done by a qualified technician.

ALWAYS DISCONNECT POWER TO THE SYSTEM WHEN SERVICING OR MAINTAINING THE EQUIPMENT. FAILURE TO DISCONNECT POWER MAY CAUSE INJURY OR DEATH.

Oil Recommendation

Use: Mobil Glycoil 30, Shell-Tivela 220, Texaco-Synoil, SG-XP220, Esso-S220, Telesia Oil 150, BP-Energol SG -XP 220 Synthetic Oil.

1. Periodically check and tighten the delivery system hardware.
2. Grease boot bearings on grease fittings regularly, using an automotive or industrial type grease.
3. Keep the FLEX-AUGER® tubes level. Adjust if necessary. Wear increases at the points where tubes sag.
4. Replace the Plastic Shipping Plug in the power unit gear head with the Vented Plug during installation of the Power Unit.
5. Check the oil level in the gear heads at installation and every 6 months. The Pipe Plug, on the side of the gear head, indicates proper oil level. Add SAE 40W oil when necessary.
The oil in the gear heads should be replaced every 12 months with new SAE 40W oil.

- A. Remove the bottom Pipe Plug to drain the oil. Discard used oil in accordance with local and national codes.
- B. Wipe any debris off the magnet on the bottom Pipe Plug and reinstall. Remove the side Pipe Plug and (top) Vent Plug.
- C. Set the power unit in the horizontal position.
- D. 2-Stage Gear Heads(3261-1,3261-2, 3261-5, 3261-6, 3261-7, 3261-8, 3261-10, 3261-11, 3261-13, 3261-16, 3261-17): Add approximately 9 oz. (266 ml) of SAE 40W oil through top hole. This should be just enough oil to reach the side Pipe Plug.

3-Stage Gear Heads 3261-14, 3261-15, 3261-21, 3261-22): Add approximately 13 oz. (384 ml) of SAE 40W oil through top hole. This should be just enough oil to reach the side Pipe Plug.

- E. Install the side Pipe Plug and (top) Vent Plug.

6. If the system is not to be used for an extended period of time, remove all the feed from the auger lines.

Disconnect power to the system to prevent accidentally starting the system.

7. If the system must be disassembled, extreme caution must be used to prevent injury from springing auger.

- A. Disconnect power to the entire system.
- B. Pull the Anchor and Bearing Assembly and approximately 18" (45 cm) of auger out of the boot.
- C. Place a clamp or locking pliers on the auger to prevent it from springing back into the auger tubes.
- D. Remove Anchor and Bearing Assembly.
- E. Carefully release the clamp securing the auger.

CAUTION: Stand clear...the auger will spring back into the tubes.

- F. Remove the remaining system components in the opposite order they were installed, according to this manual.

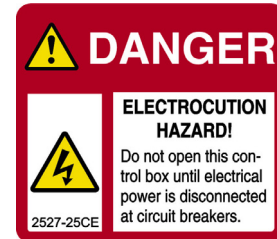

Livestock and Poultry Feed Consumption

POULTRY

Poultry applications use automatic feeding systems sized for the building density. The FLEX-AUGER® Feed Delivery System’s delivery rate should be sized to match or exceed the sum of the delivery rates of the automatic feeders supplied.

CHORE-TIME Floor Feeding Systems	Delivery Rates
Model C, C2, H2, and G with 216 RPM Power Unit.....	10.8 lbs or 4.89 kg/min.*
Model C, C2, H2, and G with 348 RPM Power Unit.....	17.0 lbs or 7.71 kg/min.*
Model ATF.....	18.0 lbs or 8.16 kg/min.*
Pan Breeder Feeder System.....	35.0 lbs or 15.87 kg/min.*
ULTRAFLO Breeder Feeder (per Hopper).....	52.0 lbs or 23.58 kg/min.*
ULTRAPAN Feeding System (per Hopper).....	50.0 lbs or 22.68 kg/min.*
*Based on 40 lbs/ft ³ density (64 kg/m ³)	
Genesis Loop (Per Inlet Boot).....	65.0 lbs or 29.48 kg/min.*
Genesis Straight-Line.....	35.0 lbs or 15.9 kg/min.*

HOGS

Live weight-lbs/Hog	Total Average Daily Feed-lbs/Head
10-25 (4.5-11.3 kg).....	1.2 (.54 kg)
25-50 (11.3-22.7 kg).....	2.5 (1.13 kg)
50-75 (22.7-34 kg).....	4.0 (1.81 kg)
75-125 (34-56.7 kg).....	5.2 (2.35 kg)
125-175 (56.7-79.4 kg).....	6.7 (3.04 kg)
175-225 (79.4-102 kg).....	7.8 (3.54 kg)
Gestating Sows.....	5 (2.26 kg)

DAIRY

Milk/Cow/Day-lbs Average	Concentrates*/Cow/Day-lbs Average
30 (13.61 kg)	10 (4.53 kg)
50 (22.68 kg)	20 (9.07 kg)
70 (31.75 kg)	30 (13.61 kg)
80 (36.28 kg)	40 (18.14 kg)

TO DETERMINE THE RUNNING TIME PER DAY-Multiply the number of animals by the feed consumption/head figures from the charts to get Total Feed Consumption.

-Divide Total Feed Consumption by the stated delivery rate of the FLEX-AUGER® Feed Delivery System to get running time per day in minutes. Divide this by 60 to get running time per day in hours.

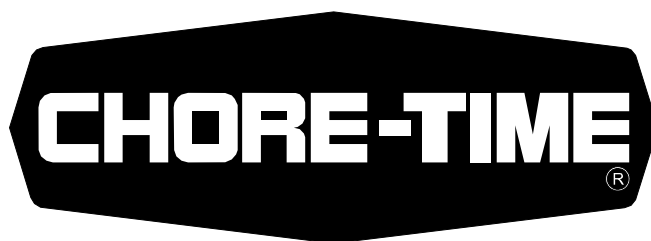

MADE TO WORK.

BUILT TO LAST.®

Revisions to this Manual

Page No.	Description of Change	ECO
Various	Updated to CE standards.	
25	Updated to 2148 Lock Nut	34835
33	Changed 4347 to 4347R/C, 6093 to 6093R/C, 2128 to 2128-100, 34633 to 47862-0, Removed 34354 & 34355	
34	Removed 3259-90, Changed 3085-4 to 3085	
35	Changed 4270 to 2805, Removed 3259-90	
39,40	Added 56705, Changed 2146 to 2148, 4347 to 4347R/C, 6093 to 6093R/C, 2128-1 to 2128-250	
41	Changed 2146 to 2148, 6093 to 6093R/C, 2128-1 to 2128-250	

**For additional parts and information, contact your nearest Chore-Time distributor or representative.
Find your nearest distributor at: www.choretime.com/contacts**

CTB, Inc.
PO Box 2000
Milford, Indiana 46542-2000 USA
Phone (574) 658-4101 Fax (877) 730-8825
Email: choretime@choretime.com
Internet: www.choretime.com